

Overview

This publication describes the installation procedure for the 4100-5128 Battery Distribution Terminal Module (450-323). The 4100-5128 is a general-purpose module that can be used with 2120 utility cabinets and external battery cabinets. It is always mounted to 4100 back boxes, and can also be mounted to 4100U and 4100ES back boxes.

The battery distribution terminal module is shown below.

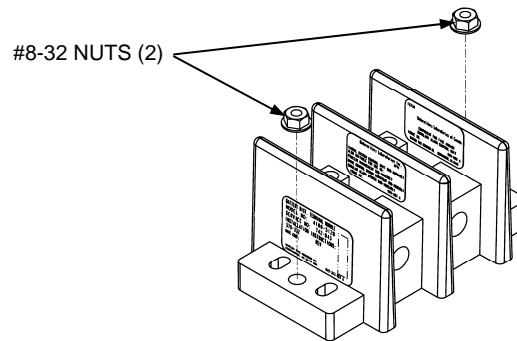

Figure 1. 4100-5128 Battery Distribution Terminal Module

Mounting the 4100-5128

Install the battery distribution terminal module onto the two mounting studs on the right side of the back box as shown in Figure 2.

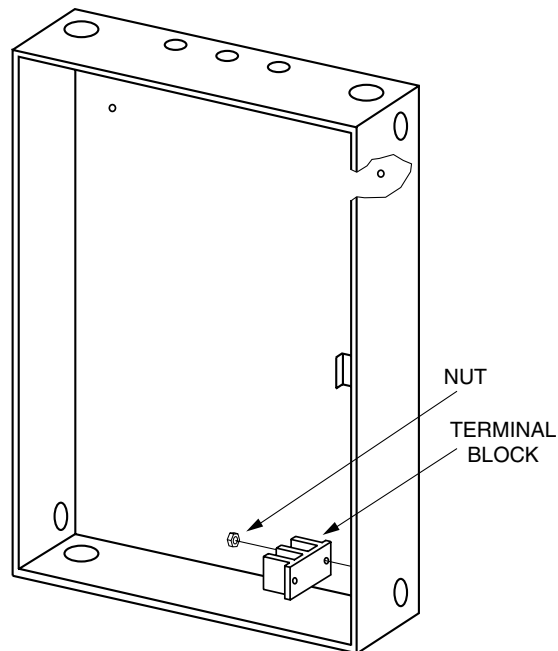

Figure 2. Mounting

Continued on next page

Installation Instructions, *Continued*

Wiring the 4100-5128

Figure 3, below, shows typical battery block connections for all types of applicable cabinets.

- Line side wire range: #2/0 to #14 AWG, Copper/Aluminum
- Load side wire range: #6 to #14 AWG, Copper/Aluminum

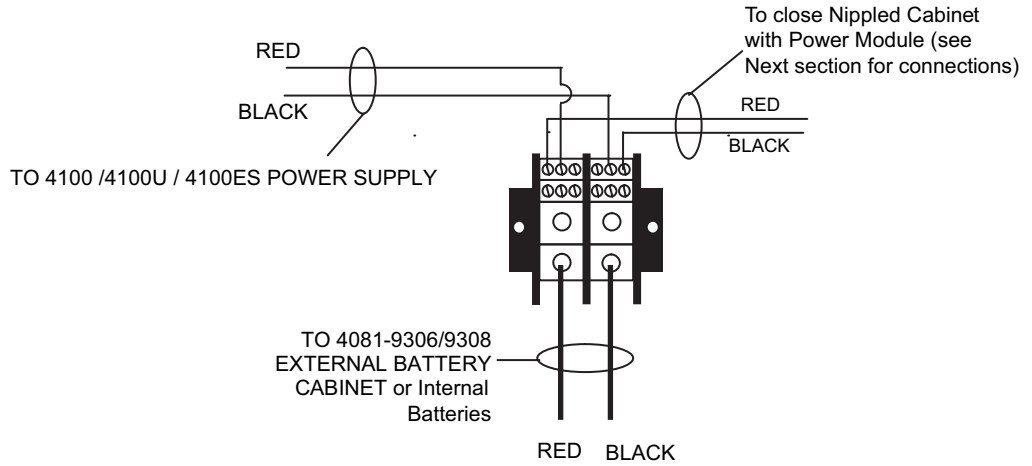

Figure 3. Wiring

For additional wiring instructions, refer to the next section and the following publications:

- *4100ES Fire Alarm System Installation Guide (574-848)*
- *4100-9306/9308 External Battery Charger Installation Instructions (579-268)*
- *XPS and XNAC Installation Instructions (574-772)*
- *2081-9280 Remote Battery Cabinet Installation Instruction (574-670)*

Wiring Close-Nippled Power Modules

Wiring Close-Nippled Power Modules

This section describes the required battery wiring between multiple, close-nippled cabinets when no transponder interface cards (TICs) are used. This is necessary to interconnect 0 V references to close-nippled cabinets.

Figure 4 illustrates this situation. Observe +/- polarity when wiring blocks from cabinet to cabinet, as shown in Figure 3.

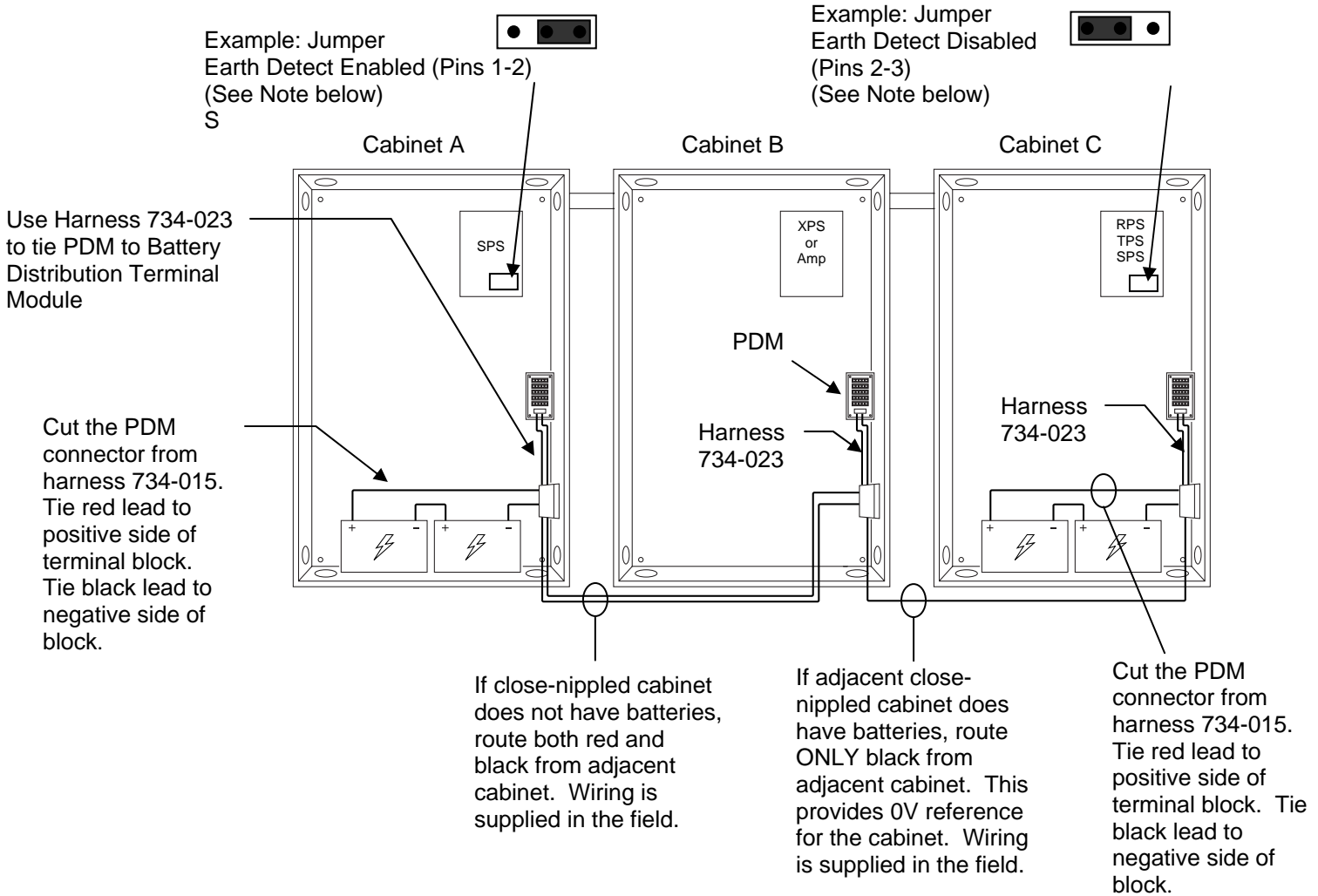

Figure 4. Wiring Batteries between Close Nippled Cabinets, No TICs Used

In the example shown in Figure 4, the power supply in Cabinet B receives battery backup from the battery set in Cabinet A. Battery power passes from Cabinet A to B via the red and black wires. Earth fault detection is from the SPS in Cabinet A. Enable Earth Detect on the SPS by setting jumper P7 on the SPS to position 1-2 (Right). See Figure 4.

The charger in Cabinet C is charging a separate set of batteries. Only the black wire (0V) is connected. Disable the Earth Detect circuit on the RPS/SPS by moving the jumper on P7 to position 2-3 (Left). Note that for systems with 1-or-more TPS units, one of the TPS Earth Detect circuits must be enabled, with all others disabled. See Figure 4.

