



8-inch Speaker and Speaker-Strobe

964 & 965 Series



Overview

EST's 964 and 965 Series Speaker and Speaker-Strobes are designed for broadcasting high quality, integrated, emergency voice communications, alert and alarm tone signals. Use them in life safety applications, especially to notify the hearing impaired, where transitory people are expected such as hotels, malls, airports, hospitals and other public buildings.

Speakers are shipped complete with a 'DC Blocking Capacitor' to permit electrical supervision of the audio distribution circuit. Use the 964 series for 25 Vrms circuits; the 965 series for 70 Vrms circuits. The large eight-inch speaker cone offers a wide frequency response to improve audibility and intelligibility. Wattage taps from ½ to 4 watts provide on-site flexibility where higher or lower dB output is desired. Wattage tap selection is easy; just move the slide-on connector on the speaker's terminal block.

The 12½ inch (318 mm) diameter steel baffle is finished with an attractive yet durable, high quality, baked white epoxy polyester powder-coat. The speakers flush mount to EST's custom 960A-8SF box. The flush box is made from satin-coat steel and has flexible mounting straps for easy installation with poured concrete forms.

The flash from Edwards strobes will be noticed from almost any position in the room, corridor, or large open space. The output is controlled using a specially shaped reflector to ensure precise dispersion of the light in all viewing directions. Edwards strobes are UL1971 listed with both wall and ceiling cd intensity ratings (see Specifications). This is useful in areas where the Authority Having Jurisdiction (AHJ) permits ceiling mount strobes.

Standard Features

- High fidelity**
 Large eight-inch speaker cone offers a wide frequency response to improve audibility and intelligibility
- 25 and 70 volt RMS models**
 All speakers include a DC Blocking Capacitor for audio circuit supervision.
- Screw terminal wire connection**
 Connect for ½, 1, 2, or 4 watt operation on terminal block. Terminals speed installation and accept up to #14 AWG (1.95 mm²) wire.
- UL 1971-listed synchronizing strobe**
 Integrity strobes synchronize to the latest UL 1971 requirements when used with a synchronization source.
- Genesis-compatible**
 All Genesis and Integrity strobes on the same circuit meet UL 1971 synchronization requirements when used with an external control module.
- Approved for public and private mode applications**
 UL 1971-listed as signaling devices for the hearing impaired and UL 1638-listed as protective visual signaling appliances.
- Field changeable field markings**
 Lens language or standard "FIRE" marking is easily changed with optional LKW and LKC series lens kits.

Application

NOTE: The installation of visible and audible signals are subject to national and local standards, codes, and ordinances. Consult your Authority Having Jurisdiction for device installation requirements, application standards, and minimum performance specifications.

Speakers

All 964 and 965 Series speakers include a DC blocking capacitor to allow electrical supervision of the audio distribution circuit. Models for 25 V_{RMS} and 70 V_{RMS} circuits are available. Wattage taps from 1/2 W to 4 W provide on-site flexibility.

The suggested sound pressure level for each signaling zone used with alert or alarm signals is a minimum of 15 dB above the average ambient sound level or 5 dB above the maximum sound level having a duration of at least 60 seconds, whichever is greater. This is measured 5 feet (1.5 m) above the floor. The average ambient sound level is the RMS, A-weighted sound pressure measured over a 24-hour period.

Doubling the distance from the signal to the ear will theoretically cause a 6dB reduction in the received sound pressure level. The actual effect depends on the acoustic properties of materials in the space. Doubling the power output of a device (e.g.: a speaker from 1W to 2W) will increase the sound pressure level by 3dBA. A 3dBA difference represents a barely noticeable change in volume.

Strobes

Edwards strobes are UL 1971-listed for use indoors as wall-mounted or ceiling-mounted public-mode notification appliances for the hearing impaired. Prevailing codes require strobes to be used where ambient noise conditions exceed specified levels, where occupants use hearing protection, and in areas of public accommodation. Consult with your Authority Having Jurisdiction for details.

As part of the Enhanced Integrity line of products, 964 and 965 Series strobes exceed UL synchronization requirements (within 10 milliseconds other over a two-hour period) when used with a synchronization source. Synchronization is important in order to avoid epileptic sensitivity.

Integrity strobes are fully compatible with Edwards Genesis signals.

NOTE: The flash intensity of some visible signals may not be adequate to alert or waken occupants in the protected area. Research indicates that the intensity of strobe needed to awaken 90% of sleeping persons is approximately 100 cd. Edwards recommends that strobes in sleeping rooms be rated at at least 110 cd.

WARNING: These devices will not operate without electrical power. As fires frequently cause power interruptions, further safeguards such as backup power supplies may be required.

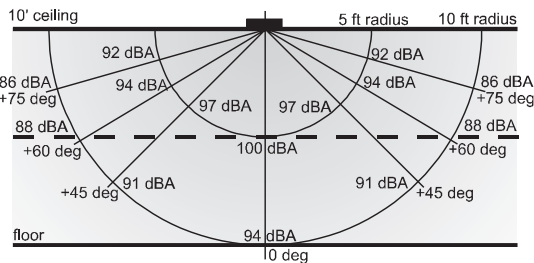

Typical Sound Output - eight-inch Speaker dBA measured in anechoic chamber
964/965 Series SPEAKER

Light Output Patterns

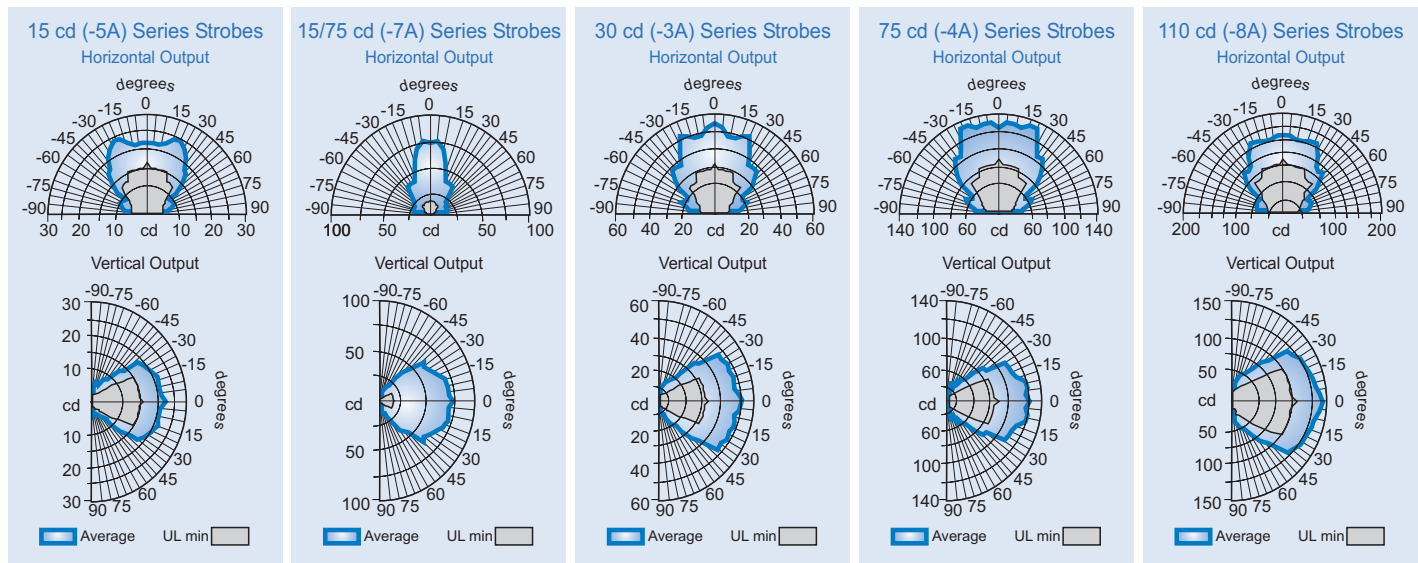

Installation and Mounting

All models flush mount to EST's 960A-8SF Square Flush Box and surface mount to 960A-8SS Square Surface Box. Edwards recommends that fire alarm speakers and speaker/strobes always be installed in accordance with the latest recognized edition of national and local fire alarm codes.

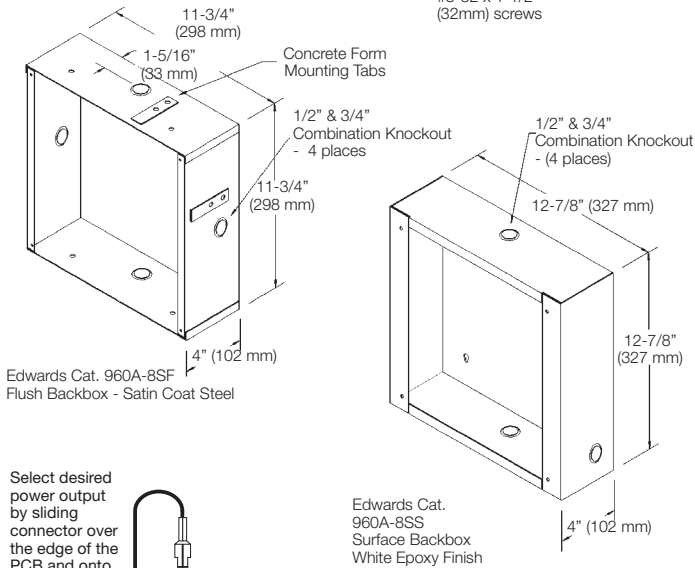
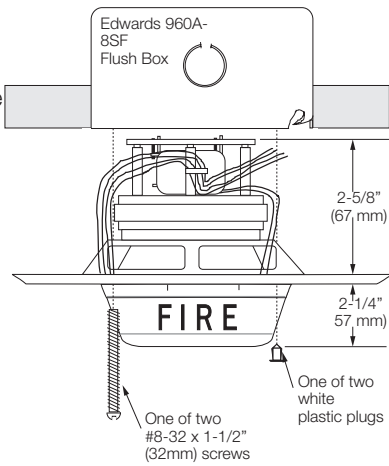

Edwards Cat. 960A-8SF
Flush Backbox - Satin Coat Steel

Edwards Cat.
960A-8SS
Surface Backbox
White Epoxy Finish

Select desired power output by sliding connector over the edge of the PCB and onto the contact pad.

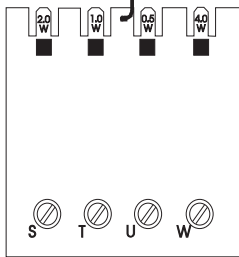

Typical Wiring

Connect 964 Series speakers to 25 Vrms audio circuits. Connect 965 Series speakers to 70 Vrms audio circuits. The strobe must be connected to signal circuits which output a constant (not pulsed) 24 Vdc voltage.

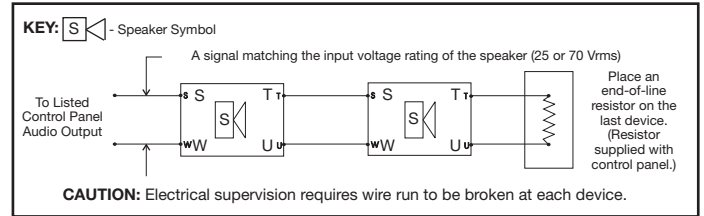

Figure 1: Wiring Diagram for Speaker

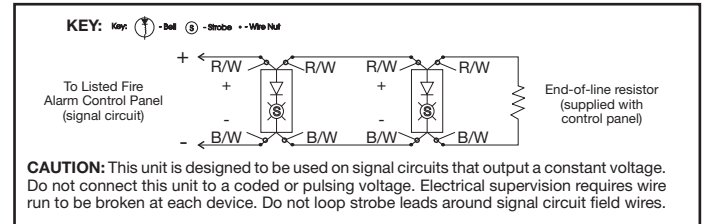

Figure 2: Wiring Diagram for Strobe

Strobe Operating Current (RMS)

UL Rating	15 cd	15/75 cd	30 cd	75 cd	110 cd
16 Vdc	109	150	130	263	329
16 Vfwr	150	210	189	333	420

Typical Current	15 cd	15/75 cd	30 cd	75 cd	110 cd
24 Vdc	69	90	89	159	180
24 Vfwr	108	128	134	255	260

Vdc: Volts direct current, regulated and filtered
Vfwr: Volts full wave rectified

Current Draw Notes and Comments

1. Current values are shown in mA.
2. UL Nameplate Rating can vary from Typical Current due to measurement methods and instruments used.
3. Edwards recommends using the Typical Current for system design including NAC and Power Supply loading and voltage drop calculations.
4. Use the 16 Vdc RMS current ratings for filtered power supply and battery AH calculations. Use the 16 Vfwr RMS current ratings for unfiltered power supply calculations.
5. Fuses, circuit breakers and other overcurrent protection devices are typically rated for current in RMS values. Most of these devices operate based upon the heating affect of the current flowing through the device. The RMS current determines the heating affect and therefore, the trip and hold threshold for those devices.

Specifications

Rated Strobe Output (cd)	964/965-5A-8SW	964/965-7A-8SW	964/965-3A-8SW	964/965-4A-8SW	964/965-8A-8SW
UL 1638/ULC S526 Rated Strobe Output	15cd	75cd	30cd	75cd	110cd
UL 1971 Rated Strobe Output (cd)	15cd (wall only)	15cd (wall or ceiling)	30cd (wall) 15cd (ceiling)	75cd (wall) 60cd (ceiling)	110cd (wall) 60cd (ceiling)
Input/Operating Volts	Speaker: 25 VRMS (964 Series) or 70 VRMS (965 Series) - see ordering table Strobe: 16-33 Vdc Continuous				
Speaker Taps/Output (note 1)	Measured at 10 ft (3.05 m): 4W = 88 dBA, 2W = 85 dBA, 1W = 82 dBA, 1/2W = 79 dBA				
Strobe Flash Synchronization	Synchronized at one flash per second. External control module necessary to meet UL 1971 synchronization requirements of 10 milliseconds over a two-hour period.				
Synchronization Sources	G1M-RM, SIGA-CC1S, SIGA-MCC1S, BPS6, BPS10				
Strobe Lens Markings	Supplied with LKC-1 "FIRE" red letters, horizontal both sides (Ceiling Mount) - see LKW and LKC series for wall mount style and optional markings				
Flash Tube Enclosure	Clear LEXAN with snap-on white markings sleeve				
Speaker Cone	8" (200 mm) cone rated for 5 watts, 8 ohm voice coil, 152 gram (5.36 oz) ceramic magnet				
Response	100 Hz - 8 KHz +/- 5 dB				
Baffle	Steel, baked epoxy polyester powder-coat finish - WHITE				
Wire Connections	Terminals (polarized) for Speaker - #14 AWG (1.95 mm ²) maximum. Color-coded polarized wire leads for strobe (2-INS/2-OUTs).				
INDOOR Operating Environment	32-120° F (0-49° C) ambient temperature. 85% relative humidity @ 30° C.				
Mounting - INDOOR	Flush: 960A-8SF Square Flush Box Surface: 960A-8SS Square Surface Box				
Agency Listings	UL 1971, UL 1638, UL 1480, ULC S526, ULC S541, FM, CSFM, MEA (All models comply with ADA Code of Federal Regulation Chapter 28 Part 36 Final Rule)				

Note 1 - Measured in reverberant room using 400 - 4000 Hz band limited pink noise per UL1480.

Ordering Information

Catalog Number	Description	Ship Wt. - lb. (kg)
25 Volt Speakers		
964-1A-8SW	Speaker, White	3.2 (1.4)
25 Volt Speaker/Strobes		
964-5A-8SW	Speaker-Strobe, 15cd, White	3.5 (1.6)
964-7A-8SW	Speaker-Strobe, 15/75cd, White	
964-3A-8SW	Speaker-Strobe, 30cd, White	
964-4A-8SW	Speaker-Strobe, 75cd, White	
964-8A-8SW	Speaker-Strobe, 110cd, White	
70 Volt Speakers		
965-1A-8SW	Speaker, White	3.2 (1.4)

70 Volt Speaker/Strobes		
965-5A-8SW	Speaker-Strobe, 15cd, White	3.5 (1.6)
965-7A-8SW	Speaker-Strobe, 15/75cd, White	
965-3A-8SW	Speaker-Strobe, 30cd, White	
965-4A-8SW	Speaker-Strobe, 75cd, White	
965-8A-8SW	Speaker-Strobe, 110cd, White	

Strobes are shipped with standard ceiling mount style "FIRE" lens markings. Where wall orientation, other languages, or different lens markings are required, Edwards offers optional LKW and LKC series Lens Marking Kits. These optional lens markings simply snap on to the strobe. Consult Edwards for availability of special lens markings.

Catalog Number	Description	Ship Wt. - lb. (kg)
Synchronization Sources		
G1M-RM	Genesis Signal Master Remote Mount (1-gang)	0.2 (0.1)
SIGA-CC1S	Synchronization Output Module (Standard Mount) - UL/ULC Listed	0.5 (0.23)
SIGA-MCC1S	Synchronization Output Module (UIO Mount) - UL Listed	0.18 (0.08)
BPS6A	6.5 Amp Booster Power Supply	13 (5.9)
BPS10A	10 Amp Booster Power Supply	13 (5.9)

Mounting Accessories		
960A-8SS	Square Surface Box, Indoor	2.5 (1.1)
960A-8SF	Square Flush Box, Indoor	

Lens Marking Kits*		
LKW-1	"FIRE", Wall Orientation	0.2 (.1)
LKW-2	"FEU", Wall Orientation	
LKW-3	"FIRE/FEU", Wall Orientation	
LKW-4	"SMOKE", Wall Orientation	
LKW-5	"HALON", Wall Orientation	
LKW-6	"CO2", Wall Orientation	
LKW-7	"EMERGENCY", Wall Orientation	
LKW-8	"ALARM", Wall Orientation	
LKW-9	"FUEGO", Wall Orientation	

*Change "W" to "C" for Ceiling Mount (e.g. LKC-1)"



Contact us...

Email: edwards.fire@fs.utc.com

Web: www.est-fire.com

EST is an **EDWARDS** brand.

1016 Corporate Park Drive
Mebane, NC 27302

In Canada, contact Chubb Edwards...

Email: inquiries@chubbedwards.com

Web: www.chubbedwards.com

© 2013 UTC Fire & Security Americas Corporation, Inc. All rights reserved. Specifications subject to change without notice. Edwards is part of UTC Climate, Controls & Security, a unit of United Technologies Corporation.
