

**IDP-RELAYMON-2  
Multiple Module with Two Relay Outputs  
and Two Monitor Inputs**

12 Clintonville Road, Northford, CT 06472-1610  
Phone: 203-484-7161 Fax: 203-484-7118  
www.Farenhyt.com

**SPECIFICATIONS**

|                                |   |
|--------------------------------|---|
| Normal Operating Voltage:      | 15 to 32 VDC  |
| Maximum Current Draw:          | 24 mA (4 LEDs on)   |
| Average Operating Current:     | 1.3 mA, 1 communication every 5 seconds   |
| Temperature Range:             | 32°F to 120°F (0°C to 49°C)   |
| Humidity:                      | 10% to 93% Non-condensing   |
| Addressing:                    | Module base address = Relay Output #1, Module base address + 1 = Monitor Input #1,<br>Module base address + 2 = Relay Output #2, Module base address + 3 = Monitor Input #2 |
| Dimensions:                    | 4.675" H x 4.275" W x 1.4" D (Mounts to a 4" square by 2 1/8" deep box.)  |
| Accessories:                   | SMB500 Electrical Box; EA-CB Barrier  |
| Relay Contact Rating:          | 3A at 30 VDC  |
| EOL Resistance:                | 47K Ohms (monitor inputs only)  |
| Maximum IDC wiring resistance: | 1500 Ohms   |
| Maximum IDC Voltage:           | 10.2 Volts  |
| Maximum IDC Current:           | 450µA   |

**RELAY CONTACT RATINGS:**

| CURRENT RATING | MAXIMUM VOLTAGE | LOAD DESCRIPTION | APPLICATION |
|----------------|-----------------|------------------|-------------|
| 2 A            | 25 VAC          | PF = 0.35        | Non-coded   |
| 3 A            | 30 VDC          | Resistive        | Non-coded   |
| 2 A            | 30 VDC          | Resistive        | Coded       |
| 0.46 A         | 30 VDC          | (L/R = 20ms)     | Non-coded   |
| 0.7 A          | 70.7 VAC        | PF = 0.35        | Non-coded   |
| 0.9 A          | 125 VDC         | Resistive        | Non-coded   |
| 0.5 A          | 125 VAC         | PF = 0.75        | Non-coded   |
| 0.3 A          | 125 VAC         | PF = 0.35        | Non-coded   |

**BEFORE INSTALLING**

This information is included as a quick reference installation guide. Refer to the control panel installation manual for detailed system information. If the modules will be installed in an existing operational system, inform the operator and local authority that the system will be temporarily out of service. Disconnect power to the control panel before installing the modules.

NOTICE: This manual should be left with the owner/user of this equipment.

**GENERAL DESCRIPTION**

The IDP-RELAYMON-2 multi output-input module is intended for use in intelligent, two-wire systems, where the individual address of each module is selected using the built-in rotary dial switches. It is capable of replacing two individual relay control modules and two Class B monitor modules. Each relay output is intended for Form C switching applications which do not require wiring supervision for the load circuit. Each monitor input is intended to interface between a fire alarm control panel and one or more devices. Each relay output has its own green LED. Each monitored input has its own bi-color LED, which can be controlled by the control panel.

The module address is selected by means of rotary dial address switches (See Figure 1). These can be accessed from the front of the module. A screwdriver should be used to rotate the wheels to select the desired addresses. Each module can use up to four (4) addresses. The base address selected via the rotary address switches will be assigned to relay output #1 from 00 to 156. The module will automatically assign the next three addresses as appropriate to monitored input #1, relay output #2, and monitored input #2.

If relay output #2 or monitored input #2 are not used, please switch the corresponding DIP switch to the 'OFF' position with the screwdriver (See Figure 1A). These two addresses will then be free to be used for other devices on the loop. NOTE: If relay output #2 is disabled and monitored input #2 is enabled, the address for monitored input #2 will be module base address + 3. Module base address + 2 (reserved for relay output #2) will then be open for other devices.

**COMPATIBILITY REQUIREMENTS**

To ensure proper operation, these modules shall be connected to listed compatible system control panels only.

**WIRING**

NOTE: All wiring must conform to applicable local codes, ordinances, and regulations.

1. Install module wiring in accordance with the job drawings and appropriate wiring diagrams.
2. Set the address on the module per job drawings.
3. Secure module to electrical box (supplied by installer), as shown in Figure 2.

NOTE: All references to power limited represent "Power Limited (Class 2)".

**FIGURE 1. CONTROLS AND INDICATORS:**

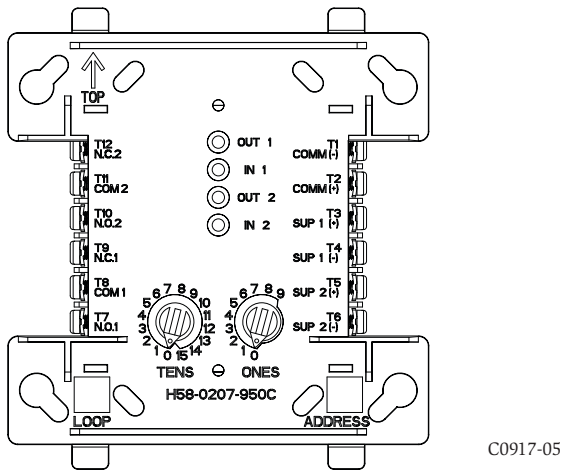

**MOUNTING**

The module mounts directly to 4-inch square electrical boxes (see Figure 2). The box must have a minimum depth of 2 7/8 inches. Surface mounted electrical boxes (SMB500) are available from System Sensor. The module can also mount to the DNR(W) duct housing.

**FIGURE 2. MODULE MOUNTING:**

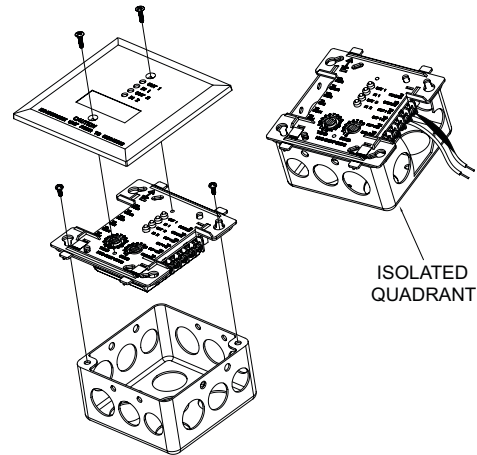

**FIGURE 1A. DISABLING OUTPUT #2 AND INPUT #2**

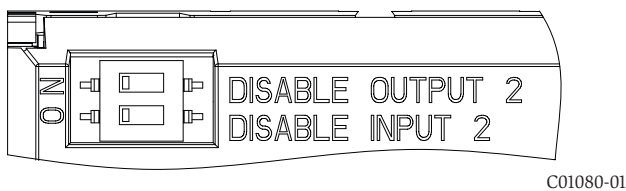

**FIGURE 3. TYPICAL 2-WIRE INITIATING CIRCUIT CONFIGURATION, NFPA STYLE B:**

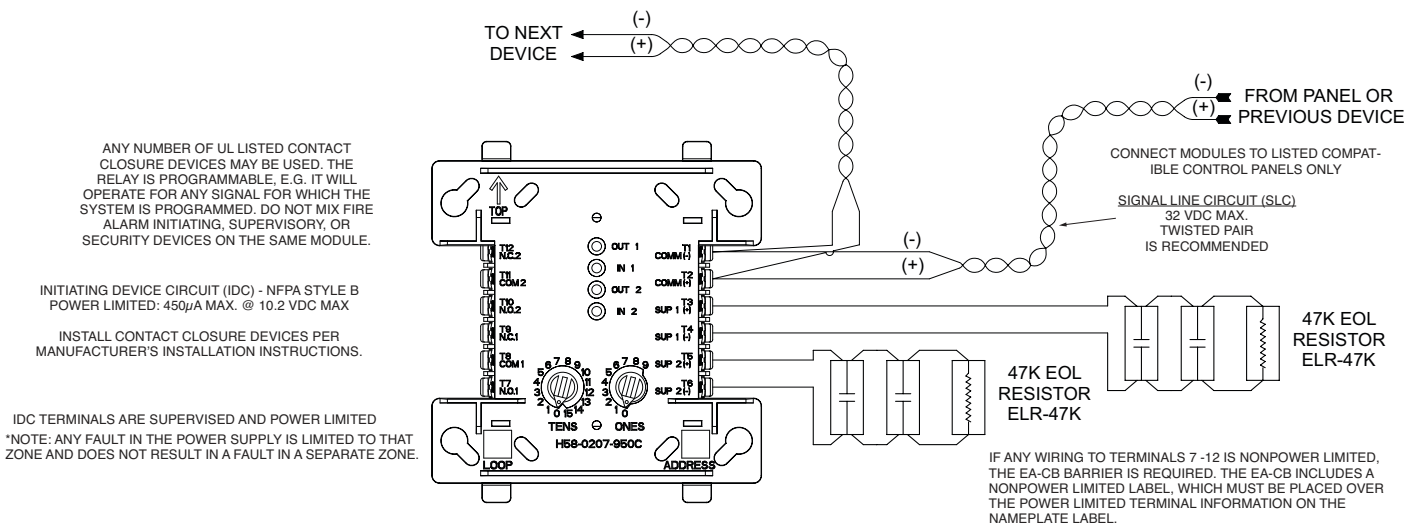

**WARNING**

All relay switch contacts are shipped in the standby (open) state, but may have transferred to the activated (closed) state during shipping. To ensure that the switch contacts are in their correct state, modules must be made to communicate with the panel before connecting circuits controlled by the module.