

LIFE SAFETY & INCIDENT MANAGEMENT

R-Series Remote Annunciators

RLCD, RLCD-C, RLED, RLED-C, RLED24, GCI



FDNY
COA 6020
COA 6087



7120-1657:
0254



Overview

EDWARDS R-Series Annunciators are high-performance remote annunciators that provide status indication and common controls for compatible fire alarm control panels, including iO-Series small analog fire alarm systems. This family of annunciators offers LCD or LED annunciation. Models are available with and without common controls.

There are three R-Series annunciator models, plus an LED-based expander. Up to two expanders can be connected to any annunciator. The expander includes 24 pairs of LEDs that extend the capabilities of any of the annunciators.

All annunciator models include status LEDs and an internal buzzer. Two models have an LCD text display, and one has 16 pairs of LEDs for zone annunciation. LCD models feature a large back-lit, four by twenty character per line, super-twist liquid crystal display.

R-Series annunciators and expanders are mounted on a standard 4-inch square electrical box, using the included mounting ring. They can also be surface mounted in locking steel enclosures. Three different enclosures are available.

A keyswitch and graphic annunciator interface is available for R-Series annunciator applications. The keyswitch enables or disables common controls. The graphic annunciator interface cards supports 32 LEDs and 16 switches on the graphic panel display.

Features

- LCD models feature large 4 x 20 character backlit LCD display
- LED models provide 16 pairs of LEDs for zone annunciation
- Available expander extends capability with 24 pairs of LEDs
- Up to two expanders may be wired to each annunciator
- Status LEDs and internal buzzer standard on all models
- Common controls available for LED and LCD display models
- Available keyswitch for disabling common controls
- Standard 4-inch square electrical box mounting
- Class B or Class A RS485 wiring standard
- One-, two-, and three-position enclosures available
- Graphic Annunciator interface, includes common control, indicators and 32 LEDs
- No programming required, set the address and unit receives all information from panel

Application

R-Series annunciators communicate with the FACP on the RS-485 data riser. This can be configured for Class A or Class B communication. Annunciators do not provide ground fault isolation.

These annunciators are stand-alone units that can be powered by the FACP or by an approved power supply.

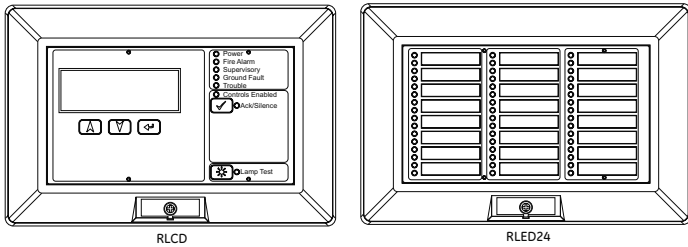
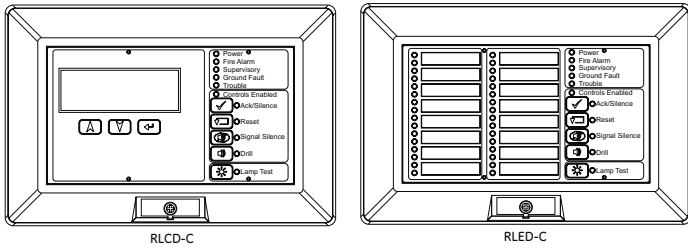

Features by model	RLCD	RLCD-C	RLED-C	RLED24
Reset	✓	✓	✓	-
Ack/Silence	✓	✓	✓	-
Fire Alarm	✓	✓	✓	-
Supervisory	✓	✓	✓	-
Ground Fault	✓	✓	✓	-
Trouble	✓	✓	✓	-
Controls Enabled	✓	✓	✓	-
Ack/Silence	✓	✓	✓	-
Reset	✓	✓	✓	-
Signal Silence	✓	✓	✓	-
Drill	✓	✓	✓	-
Lamp Test	✓	✓	✓	-
LCD Display	✓	✓	-	-
Zone Active LEDs	-	-	16 *	24 **
Zone Trouble LEDs	-	-	16	24

* zones 13-16 may be selected as Supervisory on IO64

** zones 13-16 and 29-32 may be selected as Supervisory on IO1000

Graphic Annunciator Interface

The GCI Graphic Annunciator Driver is an interface card that connects the fire alarm control panel to the display panel of an LED-based graphic annunciator.

The annunciator card supports 32 LEDs and 16 switches on the graphic panel display. It includes status LEDs and an internal buzzer.

The graphic interface is supplied with snap track mounting. It is attached to a plastic mounting rail that requires two EIA panels.

The annunciator communicates with the FACP on the RS-485 data riser. This can be configured for Class A or Class B communication. The annunciator does not provide ground fault isolation. It is a stand-alone unit that can be powered by the FACP or by an approved power supply.

Graphic Annunciator Interface Specifications

Alarm current	146 mA at 24 Vdc (with 36 LEDs ON)
Standby current	36 mA at 24 Vdc (with no LEDs ON)
Maximum current	10 mA per LED

Annunciator Wiring

Annunciator, Class A

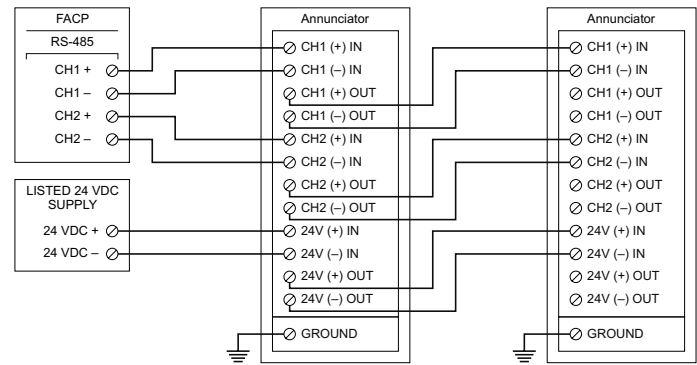

Annunciator, Class B

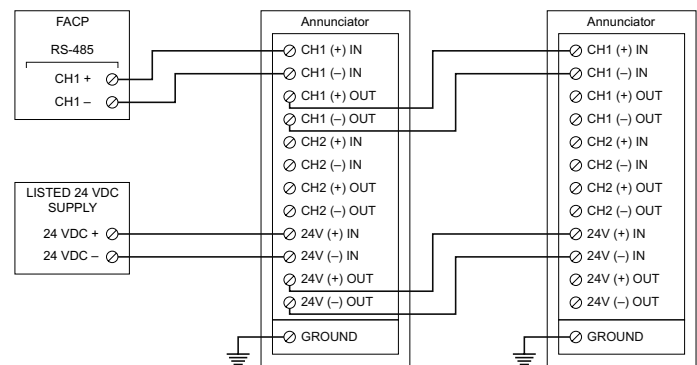

Expander

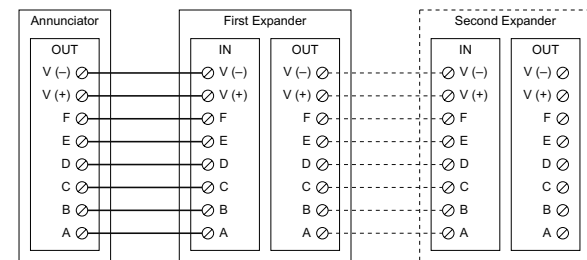

Remote Keyswitch

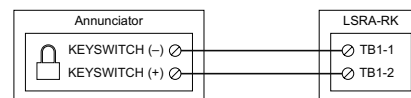

Keyswitch Specifications

Maximum voltage	5 Vdc
Maximum current	200 mA
Mounting	2-1/2 in (64 mm) deep 1-gang box
Termination	Screw terminals
Maximum wire size	12 AWG (2.5 mm sq)
Contact configuration	Normally open

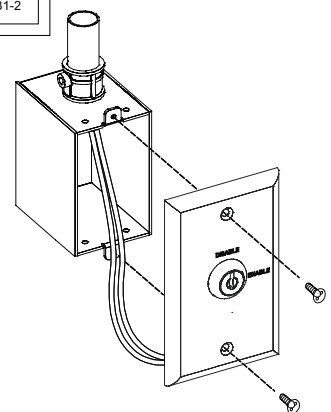

Annunciator Connections

Annunciator

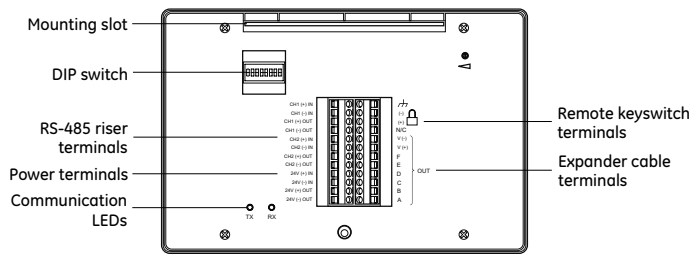

Expander

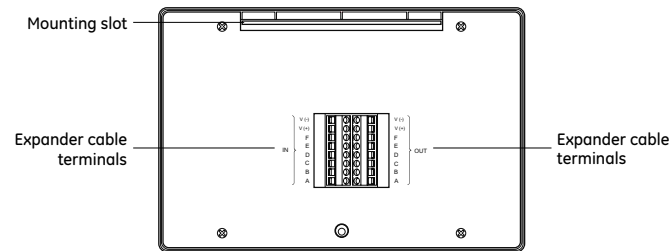

DIP switch settings

Switch	Description and values
S1 to S5	The annunciator network address (in binary). Network address Examples: 10000 = 1 01000 = 2 11000 = 3 00100 = 4
S6 Network baud rate	OFF = 9600 baud (factory default setting) ON = 38,400 baud
S7 to S8	Not used

Annunciator Mounting

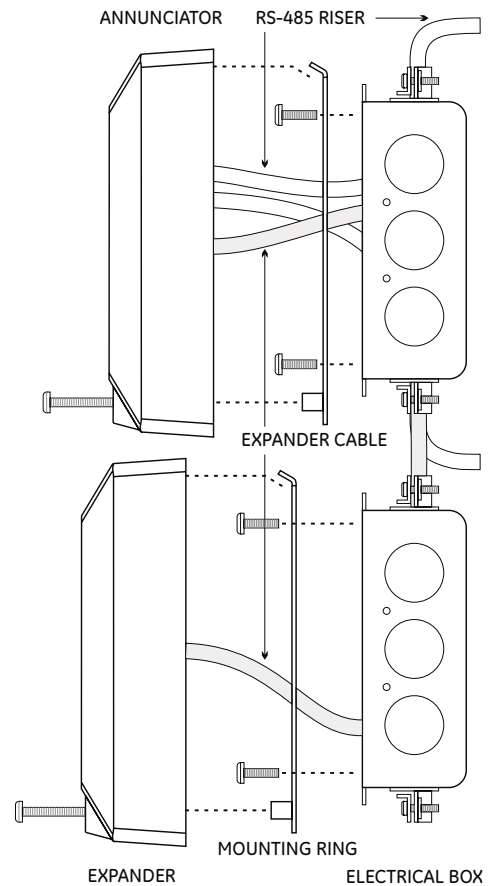

Annunciator Enclosures

The RA Remote Annunciator Enclosures provide secure, surface mounted protection for annunciators and extenders. Each consists of a back plate, hinged cover, and key lock.

The enclosures are 16-gauge welded steel with a white, painted finish. Each enclosure includes a security lock and two keys. The two- and three-position enclosures have wiring channels for correct routing of interconnections.

The enclosures attach to a standard electrical box, and provide a mounting lip that takes the place of the integral mounting ring supplied with the annunciators and expanders.

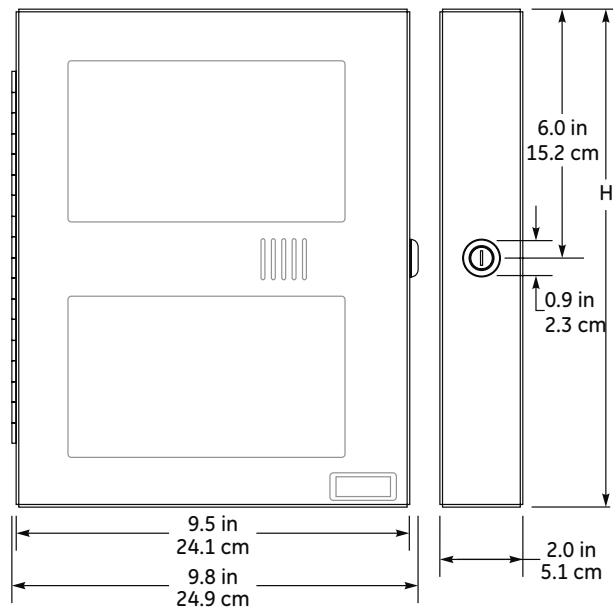
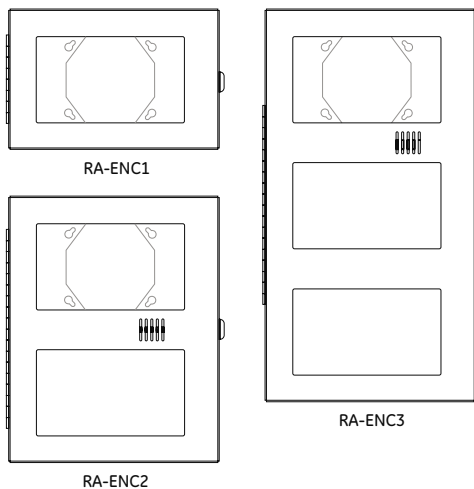

Dimensions (H x W x D)

RA-ENC1	6.3 x 9.8 x 2.0 in (16.0 x 24.9 x 5.1 cm)
RA-ENC2	12.0 x 9.8 x 2.0 in (30.5 x 24.9 x 5.1 cm)
RA-ENC3	17.7 x 9.8 x 2.0 in (45.0 x 24.9 x 5.1 cm)

Note: Allow approximately 2 inches (50 cm) clearance on both sides of the enclosure, to permit inserting and removing the key, and opening the door through 90 degrees.



LIFE SAFETY & INCIDENT MANAGEMENT

Contact us

Phone: 800-655-4497 (Option 4)
 Email: edwards.fire@carrier.com
 Website: edwardsfiresafety.com

8985 Town Center Pkwy
 Bradenton, FL 34202

© 2020 Carrier
 All rights reserved.

Specifications

	RLCD-C	RLCD	RLED-C	RLED24
Operating voltage	24 VDC, continuous.			
Standby current	99 mA	98 mA	28 mA	6 mA
Alarm current	115 mA	113 mA	62 mA	34 mA
RS-485 communications	Class A or Class B, 9600 baud			
Data wiring	18 to 14 AWG (1.0 to 2.5 sq mm) twisted pair (6 twists per foot minimum). Maximum wire run is 4,000 ft. (1,219 m)			
Remote key switch circuit	5 VDC at 1 mA, power-limited, unsupervised			
Ground fault impedance	0			
Power wiring	18 to 14 AWG (1.0 to 2.5 sq. mm)			
Display area	4 lines of 20 characters each			
Dimensions (H x W x D)	5-5/8 x 8-1/2 x 1-1/2 in. (14.3 x 21.4 x 3.8 cm)			
Mounting	North American 4-inch square electrical box or listed enclosure			
Agency Listing	UL, ULC			
Operating environment	Temperature: 32 to 120°F (0 to 49°C) Humidity: 0 to 93% RH, noncondensing at 90°F (32°C)			

Ordering Information

Part	Description
Remote Annunciators	
RLCD	LCD text annunciator without common controls. English.
RLCD-R	LCD text annunciator without common controls. English. Red.
RLCDF	LCD text annunciator without common controls. French.
RLCD-C	LCD text annunciator with common controls. English.
RLCD-CR	LCD text annunciator with common controls. English. Red.
RLCD-CF	LCD text annunciator with common controls. French.
RLED-C	16-pair LED zone annunciator with common controls. English.
RLED-CR	16-pair LED zone annunciator with common controls. English. Red.
RLED-CF	16-pair LED zone annunciator with common controls. French.
Remote Expanders	
RLED24	24-pair LED zone expander with expander cable and zone card insert.
RLED24R	24-pair LED zone expander with expander cable and zone card insert. Red.
Enclosures	
RA-ENC1	One-position enclosure for Remote Annunciator.
RA-ENC2	Two-position enclosure for Remote Annunciator and one Remote Expander, including one interconnection cable.
RA-ENC3	Three-position enclosure for Remote Annunciator and two Remote Expanders, including two interconnection cables.
LSRA-SB	Surface Mount Box - for single R Series annunciator.
Graphic Annunciator Drivers	
GCI	Graphic Annunciator Driver, provides outputs for common indicators and 32 alarm/supv zones as well as inputs for common switches. Provided with a snap track for mounting in custom graphic enclosures.
Accessories	
RKEY	Remote key switch on plate for enabling or disabling common controls (Lock/Unlock).
27193-16	Electrical box, surface mount, white, single-gang, for RKEY.