



3825 Ohio Avenue, St. Charles, Illinois 60174
1-800-SENSOR2, FAX: 630-377-6495
www.systemsensor.com

2451 and 2451TH Photoelectronic Plug-in Smoke Detectors

Specifications

Size	
Height:	2.4 inches (61 cm) Add 0.5 inches (13 cm) for thermal model 2451TH
Diameter:	4.0 inches (101 cm)
Weight:	0.5 lb. (277 g)
Operating Temperature Range:	0°C to 49°C (32°F to 120°F)
Operating Humidity Range:	10% to 93% Relative Humidity
Maximum Air Velocity:	3000 Ft./Min. (15 M/S)
Locking Alarm:	Reset by momentary power interruption
Fixed Temperature Thermal:	135°F (57°C)

Before Installing

Please thoroughly read the System Sensor publication, A05-1003, *Applications Guide for System Smoke Detectors*, which provides detailed information on detector spacing, placement, zoning, wiring, and special applications. Copies of this guide are available at no charge from System Sensor. (For installations in Canada, refer to CAN4-S524, Standard for the Installation of Fire Alarm Systems and CEC Part 1, Sec. 32.)

NOTICE: This manual should be left with the owner/user of this equipment.

IMPORTANT: This sensor must be tested and maintained regularly following NFPA 72 requirements. This sensor should be cleaned at least once a year.

General Description

The 2451 photoelectronic detectors utilize state-of-the-art, optical sensing chambers. These detectors are designed to provide open area protection, and to be used with compatible UL-listed control panels only. Model 2451TH has the same specifications as Model 2451, with the addition of a built-in fixed temperature (135°F–57°C) thermal detection unit. The capability of plugging these detectors into a variety of special bases makes them more versatile than equivalent direct-wired models.

Two LEDs on each detector light to provide a local 360° visible alarm indication. They flash every ten seconds indicating that power is applied and the detector is operating properly. The LEDs light continuously in alarm. Remote LED annunciator capability is available as an optional accessory. These detectors also have the Latching Alarm feature. The alarm can be reset only by a momentary power interruption. These detectors may be tested by activating the internal reed switch with a magnet, or by inserting a calibrated test card in a test slot after removing the detector cover.

The 2451 has been approved for marine use in dry locations by Underwriters Laboratory, Inc. The detector is to be used in dry interior locations only.

Base Selection and Wiring Guide

Refer to the installation instructions for the Plug-in Detector Bases for base selection and wiring instructions. System Sensor has a variety of detector bases available for this smoke detector. This includes 2-wire applications with and without relays and/or current limiting resistors, 4-wire and 120VAC applications. (Note: the 120VAC detector base is not available in Canada.)

All bases are provided with screw terminals for power, ground, remote annunciator connections and relay contact connections, if applicable. The electrical ratings for each detector-base combination are also included in the base installation instructions.

Installation

NOTE: Wiring must conform to applicable local codes, ordinances, and regulations.

NOTE: Verify that all detector bases are installed, that the initiating-device circuits have been tested, and that the wiring is correct. (Refer to detector base manual for testing procedure.)

WARNING

Disconnect power from initiating-device circuits before installing detectors.

1. Install detectors:
 - a. Place the detector into the detector base
 - b. Turn the detector clockwise until the detector drops into place.
 - c. Continue turning detector clockwise to lock it in place.
2. Tamper-Resistance: This detector includes a tamper-resistant feature that prevents removal of the detector without the use of a tool. To make the detector tamper-resistant, break off the smaller tab at the scribed line on the tamper-resistant tab, on the detector mounting bracket, then install the detector. To remove the detector from the bracket once it has been made tamper-resistant, use a pocket screwdriver, or similar tool, to depress the tamper-resistant tab located in the slot on the mounting bracket. Then, turn the detector counterclockwise until it separates from the base.

3. After all detectors have been installed, apply power to the control unit.
4. Test the detector using the magnet or the test card as described under TESTING.
5. Reset the detector at the system control panel.
6. Notify the proper authorities that the system is back on line.

CAUTION

Dust covers can be used to help limit dust entry to the detector, but they are not a substitute for removing the detector during building construction. Remove any dust covers before placing system in service.

CAUTION

Smoke detectors are not to be used with detector guards unless the combination has been evaluated and found suitable for that purpose.

Figure 1. Bottom and side views showing position of test magnet:

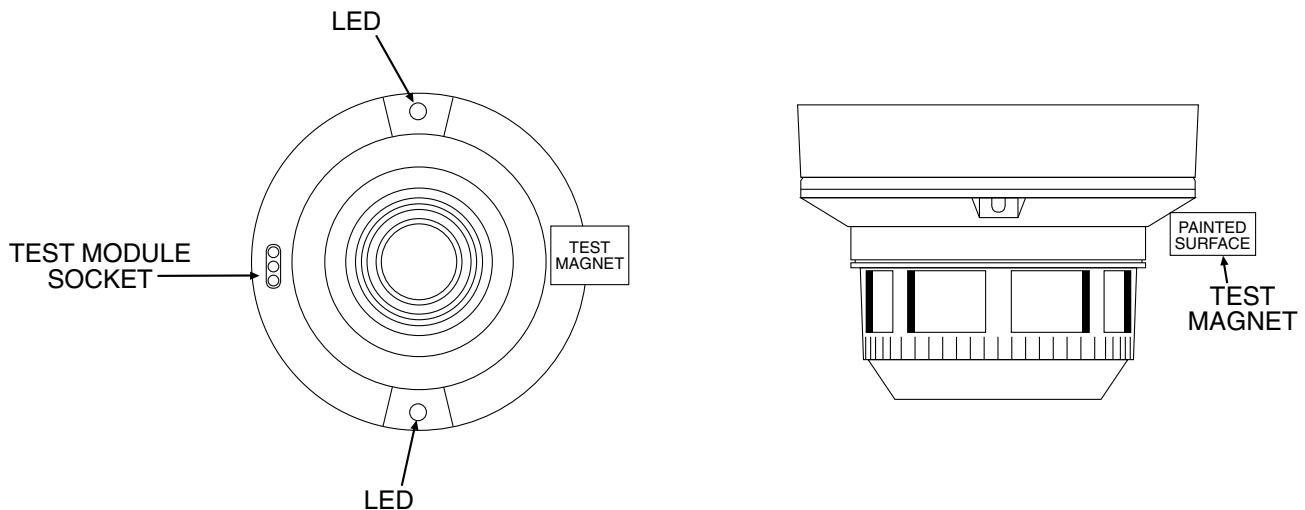

C0495-00

Testing

Before testing, notify the proper authorities that the smoke detector system is undergoing maintenance and will temporarily be out of service. Disable the zone or system undergoing maintenance to prevent unwanted alarms.

Detectors must be tested after installation and periodic maintenance. To test the 2451:

NOTE: Before testing the detector, check to ensure that the LEDs are blinking. If they are not, the detector has lost power (check the wiring) or it is defective (return for repair).

A. Test Magnet (System Sensor model no. M02-04-00)

1. Place the magnet against the cover opposite the test module slot to activate the test feature (see Figure 1).
2. The LEDs should latch on within 5 seconds indicating alarm and annunciating the panel.

B. Calibrated Test Card (System Sensor no. R59-18-00)

1. Remove the detector cover by placing a small bladed screwdriver in the side slot of the detector cover, twisting it slightly until the cover can be turned counterclockwise for removal.
2. Insert the NO ALARM end of the test card fully into the test slot (see Figure 2) then slide it counterclockwise until it stops.
3. Wait for at least 20 seconds. The detector should NOT alarm.
4. Remove the test card by sliding it clockwise before removing, then insert the ALARM end.
5. The LEDs should latch on within 20 seconds indicating alarm and annunciating the panel.
6. Put the cover back by gently rotating it clockwise until it locks in place.

C. Test Module (System Sensor no. MOD400R)

The MOD400R is used with your DMM or voltmeter to check the detector sensitivity as described in the MOD400R's manual.

D. Aerosol Generator (Gemini 501)

Set the generator to represent 4% to 5% /Ft. obscuration as described in the Gemini 501 Manual. Using the bowl shaped applicator, apply aerosol until the unit alarms.

E. Direct Heat Test (2451TH only)

To test the bi-metallic thermal collector, aim a heat source, such as a low powered heat gun or blow dryer, across the detector. Hold the heat source about 12 inches (30 cm) from the detector to avoid damaging the plastic.

When the temperature rises to greater than 135°F (57°C), the detector should latch into the alarm. The bi-metallic collector automatically resets after the test.

Notify the proper authorities that the detection system is back on line.

Detectors that fail these tests should be cleaned as described under MAINTENANCE and retested. If the detectors still fail these tests they should be returned for repair.

Figure 2:

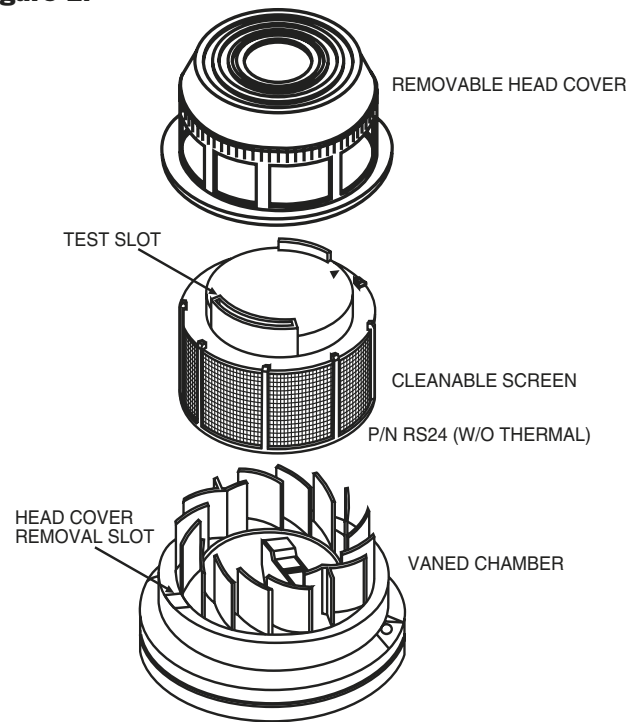

C0722-00

Maintenance

It is recommended that the detector be removed from its mounting base to facilitate easier cleaning. The detector is cleaned as follows:

NOTE: Before removing the detector, notify the proper authorities that the smoke detector system is undergoing maintenance and will temporarily be out of service. Disable the zone or system undergoing maintenance to prevent unwanted alarms.

1. Remove the detector cover by placing a small bladed screwdriver in the side slot of the detector cover, twisting it slightly until the cover can be turned counterclockwise for removal.
2. Vacuum the screen carefully without removing it. If further cleaning is required continue with Step 3, otherwise skip to Step 6.
3. Remove the screen by pulling it straight out (see Figure 2). Vacuum the inside.
4. Clean the vaned chamber piece by vacuuming or blowing out dust and particles.
5. To replace the screen, orient it so that the arrow on top aligns with the test module socket of the detector. Carefully push the screen onto the base making sure it fits tightly to the chamber.
6. Replace the cover by gently rotating it clockwise until it locks in place.
7. Reinstall the detector.
8. Notify the proper authorities that the system is back on line.

Please refer to insert for the Limitations of Fire Alarm Systems

Three-Year Limited Warranty

System Sensor warrants its enclosed smoke detector to be free from defects in materials and workmanship under normal use and service for a period of three years from date of manufacture. System Sensor makes no other express warranty for this smoke detector. No agent, representative, dealer, or employee of the Company has the authority to increase or alter the obligations or limitations of this Warranty. The Company's obligation of this Warranty shall be limited to the repair or replacement of any part of the smoke detector which is found to be defective in materials or workmanship under normal use and service during the three year period commencing with the date of manufacture. After phoning System Sensor's toll free number 800-SENSOR2 (736-7672) for a Return Authorization number, send defective units postage prepaid to: System Sensor, Repair

Department, RA #_____, 3825 Ohio Avenue, St. Charles, IL 60174. Please include a note describing the malfunction and suspected cause of failure. The Company shall not be obligated to repair or replace units which are found to be defective because of damage, unreasonable use, modifications, or alterations occurring after the date of manufacture. In no case shall the Company be liable for any consequential or incidental damages for breach of this or any other Warranty, expressed or implied whatsoever, even if the loss or damage is caused by the Company's negligence or fault. Some states do not allow the exclusion or limitation of incidental or consequential damages, so the above limitation or exclusion may not apply to you. This Warranty gives you specific legal rights, and you may also have other rights which vary from state to state.