

Eluxa outdoor 3R/4X Speaker and Speaker Strobe

EL3RSPK/EL4XSPK Speaker, EL3RSPST/EL4XSPST Speaker Strobe (Clear or amber lens)



The Wheelock Eluxa weatherproof series EL3RSPK/EL4XSPK speaker and EL3RSPST/EL4XSPST speaker-strobe appliances are designed for easy installation with a pre-wire capable EL3RBB mounting plate, or EL4XBB back box. All Eluxa weatherproof models are for indoor/outdoor use and wall or ceiling mount. The EL3RSPK/EL4XSPK and EL3RSPST/EL4XSPST Series Multi-Candela Speaker Strobes are designed for multiple power requirements with high dBA output at each power tap. The design incorporates a high efficiency speaker for maximum output at minimum power across a frequency range of 400-4000Hz.

Rugged

The cutting-edge solution delivers optimal performance thanks to its NEMA type 3R and 4X ratings, which make it resistant to corrosion and ice formation. The IP54 and IP66 ratings provide superior protection against dust and water, making it ideal for areas of high humidity, extreme heat, or severe cold.

Energy Efficient

With six candela settings in a single device, Eluxa features one of the industry's lowest current draws across the full candela range. The Eluxa outdoor product line reduces overall power consumption, allowing for more appliances on each circuit (NAC) and fewer power supplies.

Compliance and Approvals

- Certified to NEMA type 3R | 4X
- IP54 | IP66 Certified | Tested to IP67
- NFPA 72 2016 (Meets maximum light pulse duration of 20 ms)
- IEC 60529 2nd edition + amendment 3- August 2013
- FCC Part 15B / ICES-003- Class A
- UL 50 13th edition- October 2020
- UL 50E 3rd edition- October 2020
- UL464 11th edition: CAN/ULC 525 5th edition- May 2023
- UL1480 7th edition: CAN/ULC 541 5th edition- May 2023
- UL1638 6th edition: CAN/ULC 526 5th edition- April 2023
- California State Fire Marshal (CSFM) - pending
- Factory Mutual (FM) - pending
- ADA/NFPA/ANSI/OSHA

Complete and Compliant

The Wheelock Eluxa 3R/4X series meets NFPA 2016 20 millisecond light pulse duration code requirements. In addition, the Wheelock Eluxa and LED3 product lines have been UL/ULC listed as compatible with all Fire Alarm Control Panels (FACP) and accessories that have been determined to be compatible with Wheelock model RSS Strobe based products including the RSS, CH, E, EH, ET, ST, HS, MT, S8, SA, STH and Z Series. The maximum number of Eluxa devices per NAC is determined by dividing the maximum current rating of the FACP NAC by the total current rating of one Eluxa device, with a maximum of 105 Eluxa (or LED3) devices per NAC. Refer to FACP installation instructions for more detail. The Wheelock Eluxa Series and Exceder LED3 Series strobes may be installed in the same notification zone and field of view with any RSS Strobe based product.

EATON

Powering Business Worldwide

Complete and Compliant

Wheelock Eluxa 3R/4X Multi-Candela Strobes can provide a non-synchronized strobe appliance when connected directly to a Fire Alarm Control Panel (FACP), or provide a synchronized strobe appliance when used in

conjunction with an FACP that incorporates the Cooper Wheelock sync protocol, a Dual Sync Module (DSM), or the Wheelock Power Supply.

Drawings

Figure 1. Eluxa outdoor 3R

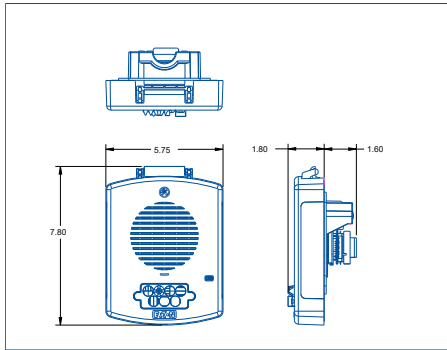

Figure 2. Eluxa outdoor 4X

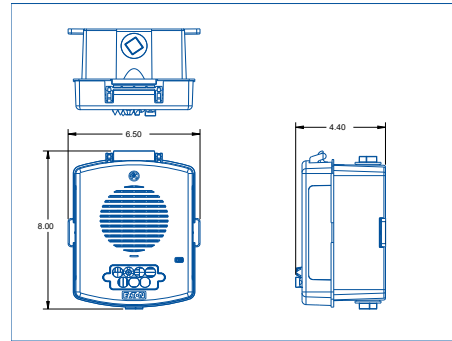

Table 1. EL3RSPK/EL4XSPK Speaker sound pressure level ratings

Setting	Reverberant dBA at 10Ft per UL1480/ULC541						
	1/8	1/4	1/2	1	2	4	8
25Vrms	76	79	82	85	88	---	---
70.7Vrms	76	79	82	85	88	91	94

Table 1A: Directional Characteristics

-3dB	+/- 80 Degrees Horizontal, +/- 80 Degrees Vertical
-6dB	+/- 90 Degrees Horizontal, +/- 90 Degrees Vertical

Table 2. EL3RSPST/EL4XSPST Speaker Strobe Ratings

Speaker Strobe (Clear)	Regulated Voltage Range VDC	UL/ULC Max Current					
		24VDC					
		15	30	75	110	150	185
EL3RSPST	16.0-33.0	0.026	0.038	0.070	0.097	0.179	0.206
EL4XSPST	16.0-33.0	0.026	0.038	0.070	0.097	0.179	0.206
	FWR	0.034	0.053	0.098	0.137	0.235	0.308
Speaker Strobe Amber (Amber strobe is certified as Emergency Warning Visual Signal.)		15	30	75	95	150	177
EL3RSPSTA (Amber)	16.0-33.0	0.026	0.038	0.070	0.097	0.179	0.206
EL4XSPSTA (Amber)	16.0-33.0	0.026	0.038	0.070	0.097	0.179	0.206
	FWR	0.034	0.053	0.098	0.137	0.235	0.308

Table 3. Specifications

Physical	
Material	Red or white textured UV stabilized, colored impregnated engineered plastic.
Weight	3R = 1.7 lbs 4X = 2.3
Lens	Light Emitting Diode (LED) in a rugged Lexan lens
Dimensions	3R: 7.8"L x 5.75"W x 1.6"H 4X: 8"L x 6.5"W x 4.5"H
Operating Temperature	Indoor/Outdoor Use. -40° C to 66° C (-40° F to 150° F) 95% R.H.
Mounting & Wire Connections	
Mounting	Wall & Ceiling
Wire Connections	18 to 12 AWG. 2 wire.
Power & General	
Operating voltage	16-33 VDC/FWR.
Strobe Output Rating	Clear 15/30/75/110/150/185 Cd Amber 15/30/75/95/150/177 Cd
Strobe Flash Rate	1 Hz
Synchronization Models	ALL

Table 4. Ordering Information

Model	Strobe Candela	Lens	Red	White	Lettering	Sync w/DSM or Wheelock Power Supplies
Speaker						
EL3RSPK-NR			X		n/a	X
EL3RSPK-NW				X	n/a	X
EL4XSPK-NR			X		n/a	X
EL4XSPK-NW				X	n/a	X
Speaker Strobe						
EL3RSPST-FR	15/30/75/110/150/185	Clear	X		FIRE	X
EL3RSPST-FW	15/30/75/110/150/185	Clear		X	FIRE	X
EL4XSPST-FR	15/30/75/110/150/185	Clear	X		FIRE	X
EL4XSPST-FW	15/30/75/110/150/185			X	FIRE	X
EL3RSPSTA-NW	15/30/75/95/150/177	Amber		X		X
EL3RSPSTA-ALW	15/30/75/95/150/177	Amber		X	ALERT	X
EL4XSPSTA-NW	15/30/75/95/150/177	Amber		X		X
EL4XSPSTA-ALW	15/30/75/95/150/177	Amber		X	ALERT	X

Table 5. Accessories

Standard Letter Plates	Color	Description
ELLP-FR (10Pk)	Red	ELUXA LETTER PLATE, RED, FIRE (10 PAIR PER PKG. - 1 PAIR PER DEVICE)
ELLP-FW (10Pk)	White	ELUXA LETTER PLATE, WHITE, FIRE (10 PAIR PER PKG. - 1 PAIR PER DEVICE)
ELLP-NR (10Pk)	Red	ELUXA LETTER PLATE, RED, NO LETTERING (10 PAIR PER PKG. - 1 PAIR PER DEVICE)
ELLP-NW (10Pk)	White	ELUXA LETTER PLATE, WHITE, NO LETTERING (10 PAIR PER PKG. - 1 PAIR PER DEVICE)
ELLP-AR (10Pk)	Red	ELUXA LETTER PLATE, RED, AGENT (10 PAIR PER PKG. - 1 PAIR PER DEVICE)
ELLP-AW (10Pk)	White	ELUXA LETTER PLATE, WHITE, AGENT (10 PAIR PER PKG. - 1 PAIR PER DEVICE)
ELLP-ALR (10Pk)	Red	ELUXA LETTER PLATE, RED, ALERT (10 PAIR PER PKG. - 1 PAIR PER DEVICE)
ELLP-ALW (10Pk)	White	ELUXA LETTER PLATE, WHITE, ALERT (10 PAIR PER PKG. - 1 PAIR PER DEVICE)

Standard Letter Plates	Color	Description
ELLP-COR (10Pk)	Red	ELUXA LETTER PLATE, RED, CARBON MONOXIDE (10 PAIR PER PKG. - 1 PAIR PER DEVICE)
ELLP-COW (10Pk)	White	ELUXA LETTER PLATE, WHITE, CARBON MONOXIDE (10 PAIR PER PKG. - 1 PAIR PER DEVICE)
ELLP-CO2R (10Pk)	Red	ELUXA LETTER PLATE, RED, CARBON DIOXIDE (10 PAIR PER PKG. - 1 PAIR PER DEVICE)
ELLP-CO2W (10Pk)	White	ELUXA LETTER PLATE, WHITE, CARBON DIOXIDE (10 PAIR PER PKG. - 1 PAIR PER DEVICE)
ELLP-EVR (10Pk)	Red	ELUXA LETTER PLATE, RED, EVACUATE (10 PAIR PER PKG. - 1 PAIR PER DEVICE)
ELLP-EVW (10Pk)	White	ELUXA LETTER PLATE, WHITE, EVACUATE (10 PAIR PER PKG. - 1 PAIR PER DEVICE)
ELLP-MR (10Pk)	Red	ELUXA LETTER PLATE, RED, EMERGENCY (10 PAIR PER PKG. - 1 PAIR PER DEVICE)
ELLP-MW (10Pk)	White	ELUXA LETTER PLATE, WHITE, EMERGENCY (10 PAIR PER PKG. - 1 PAIR PER DEVICE)
ELLP-FFR (10Pk)	Red	ELUXA LETTER PLATE, RED, FIRE / FEU (10 PAIR PER PKG. - 1 PAIR PER DEVICE)
ELLP-FFW (10Pk)	White	ELUXA LETTER PLATE, WHITE, FIRE / FEU (10 PAIR PER PKG. - 1 PAIR PER DEVICE)
Back Box	Color	Description
EL4XBB-R	Red	NEMA 4X SURFACE BACKBOX, RED
EL4XBB-W	White	NEMA 4X SURFACE BACKBOX, WHITE

Architects and Engineers Specifications

The LED outdoor notification appliances shall be Wheelock® EL3RSPK/EL4XSPK speaker EL3RSPST/EL4XSPST speaker strobe appliances for wall and ceiling-mount applications with a low-profile design or approved equals. Special lettering, including FIRE, ALERT and no lettering, shall be available. The outdoor series EL3RSPK/EL4XSPK, EL3RSPST/EL4XSPST, EL3RSPSTA/EL4XSPSTA (Amber) shall be listed for: Certified to NEMA type 3R | 4X, IP54 | IP66 Certified | Tested to IP67, NFPA 72 2016 (Meets maximum light pulse duration of 20 ms), IEC 60529 2nd edition + amendment 3- August 2013, FCC Part 15B / ICES-003- Class A, UL 50 13th edition- October 2020, UL 50E 3rd edition- October 2020, UL464 11th edition: CAN/ULC 525 5th edition- May 2023, UL1480 7th edition: CAN/ULC S541 5th edition- May 2023, UL1638 6th edition: CAN/ULC S526 5th edition- April 2023, California State Fire Marshal (CSFM)- pending, Factory Mutual (FM)- pending, ADA/NFPA/ANSI/OSHA. All inputs shall be compatible with standard reverse polarity supervision of circuit wiring by a Fire Alarm Control Panel (FACP) with the ability to operate from 16 to 33 VDC/VFWR.

The EL3RSPST/EL4XSPST speaker strobe appliances shall produce a flash rate of one (1) flash per second over the Regulated Voltage Range and shall incorporate a Light Emitting Diode (LED) as the light source with a rugged Lexan® lens. The appliances shall be of low current design. The LED strobe flash duration shall be 20 ms. Where Multi-Candela appliances are specified, the strobe intensity shall have 6 field selectable settings at 15, 30, 75, 110, 150 and 185 candela for the clear lens and 15, 30, 75, 95, 150, 177cd for the amber lens. The selector switch for selecting the candela shall be tamper resistant. Appliances with candela settings shall show the candela selection in a visible location at all times when installed.

Note: Due to continuous development of our products, specifications and offerings are subject to change without notice in accordance with Cooper Wheelock Inc., dba Eaton standard terms and conditions apply.

The outdoor series EL3RSPK/EL4XSPK, EL3RSPST/EL4XSPST, EL3RSPSTA/EL4XSPSTA (Amber) appliances shall include a mounting plate or surface mounting box from the factory. The outdoor series EL3RSPK/EL4XSPK, EL3RSPST/EL4XSPST, EL3RSPSTA/EL4XSPSTA (Amber) incorporates pre-wire, pre-test mounting plate and back box terminals. The outdoor series EL3RSPK/EL4XSPK, EL3RSPST/EL4XSPST, EL3RSPSTA/EL4XSPSTA (Amber) rated to NEMA type 3R, IP54 and NEMA type 4X, IP66 respectively, when used with the included mounting accessory. Two wire appliance wiring shall be capable of directly connecting to the mounting plate or back box. Removal of an appliance shall result in a supervision fault condition by the Fire Alarm Control Panel (FACP). All notification appliances shall be backwards compatible.

The outdoor series EL3RSPK/EL4XSPK, EL3RSPST/EL4XSPST, EL3RSPSTA/EL4XSPSTA (Amber) appliances shall provide installers ease of installation provided by the self-supporting hanging hinge feature.

When synchronization is required, the appliance shall be compatible with Wheelock’s DSM Sync Modules, PS Power Supplies, Intelligent Notification Controller, SAFEPAH products or other manufacturer’s panels with built-in Wheelock® Patented Sync Protocol. The strobes shall not drift out of synchronization at any time during operation. If the sync protocol fails to operate, the strobe shall revert to a non-synchronized flashrate and still maintain (1) flash per second over its Regulated Voltage Range.

The appliance shall also be designed so that the audible signal may be silenced while maintaining strobe activation when used with Wheelock® patented sync protocol.

Eaton
 1000 Eaton Boulevard
 Cleveland, OH 44122
 United States
 Eaton.com

Life safety & mass notification solutions
 273 Branchport Ave.
 Long Branch, NJ 07740
 Eaton.com/Lifesafetynotification

© 2025 Eaton
 All Rights Reserved
 Printed in USA
 Publication No. TD450189EN
 July 2025

Eaton is a registered trademark.

All other trademarks are property of their respective owners.

