

### Features

**Accurate and reliable heat detection for protection of property\*\***

**UL listed to Standard 521 as a rate compensated heat detector**

**Fixed temperature operation is suitable for most applications:**

- Thermistor based design is inherently rate compensated due to minimal thermal lag
- Available for 135° F (57° C) or 200° F (93° C)
- UL spacing distance is 70 ft (21.3 m)

**Available with rate-of-rise temperature detection:**

- Dual thermistor rate-of-rise operation
- For use where anticipated ambient temperature changes are less than 6° F/minute (3.33° C/minute)
- UL spacing distance is 70 ft (21.3 m)

**E-Series provides:**

- Epoxy encapsulated electronic detector design with gold plated contacts, high humidity thermistor, and stainless steel screws
- Operation for ceiling or wall mounting
- Easily tested, self-restoring operation with repeatable accuracy
- Alarm indicating LED located on detector
- Current limited alarm that is compatible with two wire initiating device circuits (IDCs)
- Designed for EMI compatibility

**Optional remote alarm indicating LED**

**Available base options:**

- Bases for 2-wire or 4-wire operation
- Auxiliary relay output (refer to selection chart on page 2 for relay ratings)
- Remote alarm indicating LED output

### Description

**Accurate Electronic Design.** Simplex® electronic heat detectors use a fast response, thermistor based design to provide temperature sensing that quickly, accurately, and consistently identifies when fixed temperatures are exceeded. The fixed temperature sensing thermistor readily tracks the local ambient temperature. This eliminates the time required to melt a lead pellet or heat a bimetallic element as occurs in mechanical heat detector designs and provides the required heat detection for most applications.

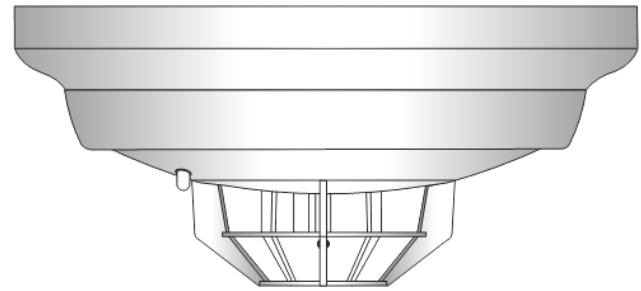

E-Series Electronic Heat Detector Mounted in Base

### Description (Continued)

**Rate-of-rise detection** is determined by comparing two thermistor responses. By combining accurate thermistors with proper physical placement, this patented rate-of-rise detection design achieves a high level of performance not normally available with mechanical detection.

### Specifications

Voltage	15 to 32 VDC (filtered DC with 30% maximum ripple)
Standby Current	80 µA typical, 100 µA maximum
Alarm Current, 2-Wire Operation	Up to 86 mA maximum, exact current is determined by alarm current limiting of connected IDC
Alarm Current, 4-Wire Operation	24 mA typical @ 24 VDC
Rate-of-Rise Operation	Meets FM requirements for operation between 15° and 25° F/min (8.33° and 13.88° C/min)
Color	Frost-White
Dimensions	Refer to diagram on page 3
Environmental Operating Range	Suitable for covered outdoor applications within the ambient conditions stated below
Humidity Range	10% to 95% RH from 32° to 122° F (0° to 50° C)
<b>Ambient Temperature Operating Range</b>	
135° F Models	32° to 100° F (0° to 38° C)
200° F Models	32° to 150° F (0° to 66° C)

**\*\* WARNING: In most fires, hazardous levels of smoke and toxic gas can build up before a heat detection device would initiate an alarm. In cases where Life Safety is a factor, the use of smoke detection is highly recommended.**

\* This product was not ULC listed or approved by CSFM or MEA (NYC) or as of document revision date. Additional listings may be applicable; contact your local Simplex product supplier for the latest status. Listings and approvals under Simplex Time Recorder Co. are the property of Tyco Safety Products Westminster.

## Applications Reference

Heat detectors are used where property protection is desired and where life safety protection is not required or is performed by other equipment. Typical heat detector applications are satisfied by use of these fixed temperature electronic detectors.

The addition of rate-of-rise operation provides two forms of heat detection for use where temperature fluctuations are controlled and are less than 6° F/min (3.33° C/min). Where temperatures may fluctuate more quickly, use fixed temperature detection.

Refer to NFPA 72, the *National Fire Alarm Code* and publication 574-709, *4098 Detectors, Sensors, and Bases Application Manual*, for additional guidance in applying and locating heat detectors.

## E-Series Products

E-Series electronic heat detectors are similar to standard Simplex indoor electronic heat detectors but are equipped with gold plated contacts, a high humidity thermistor, and stainless steel screws. For indoor heat detector applications, refer to data sheet S4098-0014.

## Alarm Indicating LED Operation

The heat detector LED turns ON continuously when in alarm. During normal conditions the LED is OFF.

## Fixed Temperature Guidelines

**135° F (57° C)** fixed temperature detectors are for normal temperatures that do not exceed 100° F (38° C).

**200° F (93° C)** fixed temperature detectors are for normal temperatures that exceed 100° F (38° C) but are less than 150° F (66° C).

## Alarm Verification Application Note

When connecting these electronic heat detectors to a 2-wire initiating device circuit (IDC) that is providing Alarm Verification for smoke detectors, use the 4098-9682E, 4-wire base. The 4-wire base provides an alarm contact that is not current-limited. (Heat detectors in the 2-wire base present a current-limited alarm condition that is not compatible with Alarm Verification. Initiating devices other than smoke detectors are required to activate the alarm without starting the alarm verification cycle.)

## Heat Detector Selection Chart (compatible with bases listed below)

Model	Fixed Temperature Operation at	Rate-of-Rise Operation	FM Ratings		UL & ULC Maximum Spacing
			Maximum Spacing	RTI (Response Time Index)	
4098-9612E	135° F (57° C)	Not applicable	20 ft x 20 ft (6.1 m x 6.1 m)	Quick	70 ft x 70 ft (21.3 m x 21.3 m)
4098-9614E	200° F (93° C)				
4098-9613E	135° F (57° C)	Between 15° & 25° F/min (8.33° & 13.88° C/min)	20 ft x 20 ft (6.1 m x 6.1 m)	Quick	
4098-9615E	200° F (93° C)		50 ft x 50 ft (15.2 m x 15.2 m)	Ultra Fast	

## Heat Detector Base Selection Chart

Model	Description	Connection	Details	
4098-9788E	<b>2-Wire Base</b> , no options	IDC connections	Screw terminals for in/out wiring, 18 to 14 AWG	
4098-9684E	<b>2-Wire Base</b> with connection for remote LED alarm indicator	IDC connections	Screw terminals for 18 to 14 AWG for in/out wiring of zone (+), color coded 18 AWG leads for in/out wiring of zone (-)	
		LED connections	Color coded 18 AWG leads	
4098-9683E	<b>2-Wire Base</b> with auxiliary alarm relay output  <b>NOTE:</b> Must be connected as the only device on the IDC to ensure relay operation.	<b>Relay Operation Type</b>	<b>Relay Ratings</b>	
		Power-limited	1 A @ 28 VDC	Dual Form "C" contacts, for suppressed loads
		Nonpower-limited	3 A @ 120 AC	
		<b>Output Type</b>	<b>Wiring Connections</b>	
		IDC connections	Screw terminals for 18 to 14 AWG for in/out wiring of zone (+), color coded 18 AWG leads for in/out wiring of zone (-)	
Relay connections	Color coded 18 AWG leads			
4098-9682E	<b>4-Wire Base</b> with auxiliary alarm relay output  <b>NOTE:</b> Requires separate 24 VDC power.	<b>Relay Operation Type</b>	<b>Relay Ratings</b>	
		Power-limited	3 A @ 28 VDC	Single Form "C" contacts, for suppressed loads
		Nonpower limited	3 A @ 120 AC	
		<b>Output Type</b>	<b>Wiring Connections</b>	
		IDC connections	Color coded 18 AWG leads for in/out wiring	
		Relay connections	Color coded 18 AWG leads	
Power connections	Screw terminals for 18 to 14 AWG for in/out wiring of power (+), color coded 18 AWG leads for in/out wiring of power (-)			

Metric wire equivalents: 18 AWG = 0.82 mm<sup>2</sup>; 14 AWG = 2.08 mm<sup>2</sup>

## Heat Detector Accessories

Model	Description	Details	Base Compatibility
4098-9832	Adapter Plate	<b>Required</b> for surface or semi-flush mounting to 4" (102 mm) square electrical box or for surface mounting to 4" octagonal box	4098-9682E 4098-9683E 4098-9684E 4098-9788E
		May also be used when retrofitting to replace existing larger diameter bases	
4098-9830	Remote Red LED Alarm Indicator	Mounted on single gang stainless steel plate, wiring connections are 18 AWG color coded leads	4098-9684E only
2098-9739	End-of-Line Relay	Epoxy encapsulated design, 24 VDC operation, wiring connections are 18 AWG color coded leads	For 4-wire IDCs using 4098-9682E base, one per circuit
2098-9735	End-of-Line Relay	Mounted on single gang stainless steel plate, 24 VDC operation, wiring connections are 18 AWG color coded leads	

Metric wire equivalent: 18 AWG = 0.82 mm<sup>2</sup>

## Dimensions and Reference

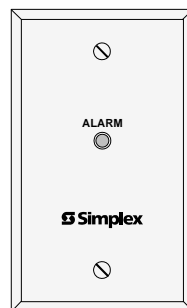
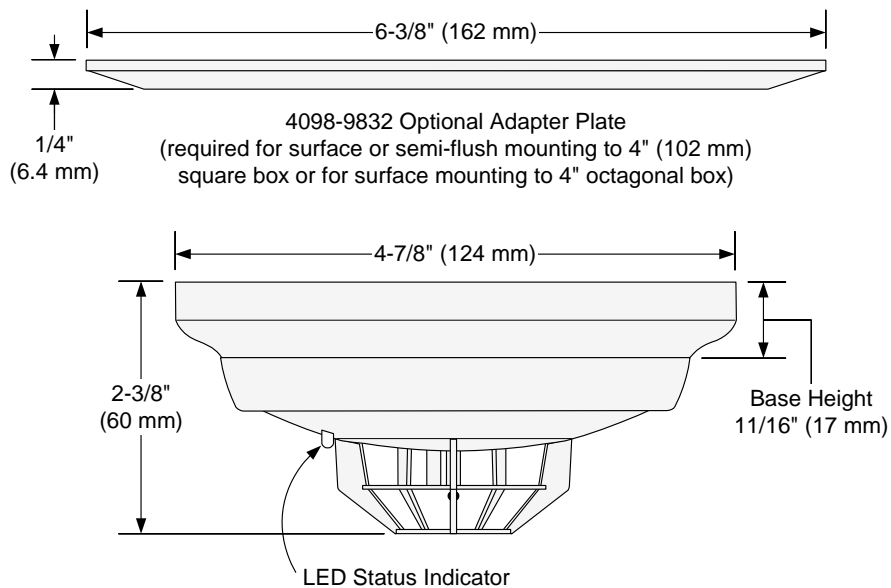

4098-9830 Remote Red LED Alarm Indicator (not to scale)

## Mounting Information

Base	Electrical Box Requirements
4098-9788E	4" (102 mm) octagonal or 4" square box, 1-1/2" deep (38 mm)
	Single gang box, 2" deep (51 mm)
4098-9682E 4098-9683E 4098-9684E	4" octagonal or 4" square box, 1-1/2" deep with 1-1/2" deep extension ring (see diagram below)

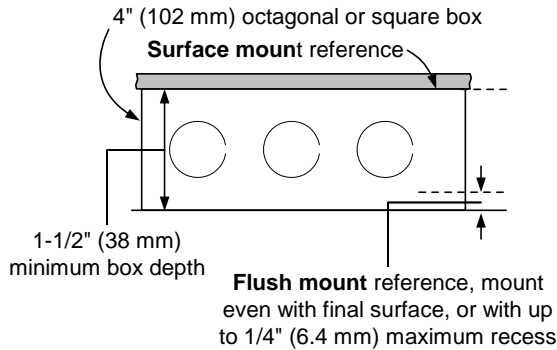

**4098-9832 Adapter Plate**, required for surface or semi-flush mounting to 4" square box or for surface mounting to 4" octagonal box

Bases 4098-9682E and 4098-9683E include a relay that mounts in base electrical box

Base 4098-9864E includes a remote LED interface module that mounts in base electrical box

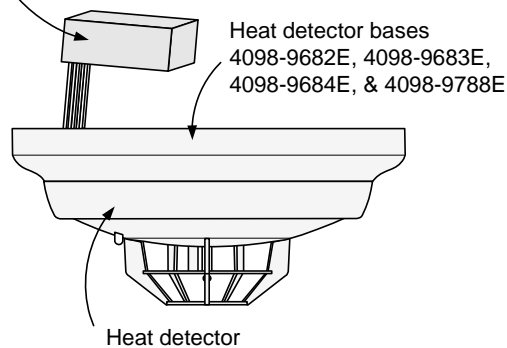

## Applications Reference

The following table provides a reference for the maximum rectangular area covered for detectors rated with the given spacing. For additional information, including consideration of ceiling height, refer to NFPA 72, the *National Fire Alarm Code*.

**Maximum Rectangular Area Dimensions for Single Detector Coverage**

20 ft Rated Spacing (6.1 m)	50 ft Rated Spacing (15.2 m)	70 ft Rated Spacing (21.3 m)
20 ft x 20 ft (6.1 m x 6.1 m)	50 ft x 50 ft (15.2 m x 15.2 m)	70 ft x 70 ft (21.3 m x 21.3 m)
15 ft x 23.9 ft (4.5 m x 7.2 m)	45 ft x 54.5 ft (13.7 m x 16.6 m)	65 ft x 74.6 ft (19.8 m x 22.7 m)
10 ft x 26.4 ft (3 m x 8 m)	40 ft x 58.2 ft (12.1 m x 17.7 m)	60 ft x 78.7 ft (18.3 m x 24 m)
5 ft x 27.8 ft (1.5 m x 8.4 m)	35 ft x 61.4 ft (10.6 m x 18.7 m)	55 ft x 82.3 ft (16.7 m x 25 m)
1 ft x 28.2 ft (0.3 m x 8.5 m)	30 ft x 64 ft (9.1 m x 19.5 m)	50 ft x 85.4 ft (15.2 m x 26 m)
	25 ft x 66.1 ft (7.6 m x 20.1 m)	45 ft x 88.1 ft (13.7 m x 26.8 m)
	20 ft x 67.8 ft (6.1 m x 20.6 m)	40 ft x 90.5 ft (12.2 m x 27.5 m)
	15 ft x 69 ft (4.5 m x 21 m)	35 ft x 92.6 ft (10.6 m x 28.2 m)
	10 ft x 69.9 ft (3.5 m x 21.3 m)	30 ft x 94.3 ft (9.1 m x 28.7 m)
	5 ft x 70.5 ft (1.5 m x 21.4 m)	25 ft x 95.7 ft (7.6 m x 29.1 m)
	1 ft x 70.6 ft (0.3 m x 21.5 m)	20 ft x 96.9 ft (6.1 m x 29.5 m)
		15 ft x 97.8 ft (4.5 m x 29.8 m)
		10 ft x 98.4 ft (3.05 m x 30 m)
		5 ft x 98.8 ft (1.5 m x 30.1 m)
		1 ft x 99 ft (0.3 m x 30.2 m)

TYCO, SIMPLEX, and the product names listed in this material are marks and/or registered marks. Unauthorized use is strictly prohibited. NFPA 72 and National Fire Alarm and Signaling Code are trademarks of the National Fire Protection Association (NFPA).



Tyco Fire Protection Products • Westminister, MA • 01441-0001 • USA

S4098-0037-2 2/2015

[www.simplex-fire.com](http://www.simplex-fire.com)

© 2015 Tyco Fire Protection Products. All rights reserved. All specifications and other information shown were current as of document revision date and are subject to change without notice.