

Features

Figure 1: TrueAlarm CO Sensor Base with Sounder, shown with 4098-9764 Photo/Heat Sensor

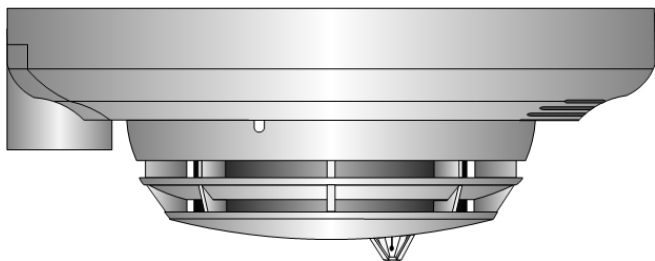

- TrueAlarm addressable CO sensor bases contain a carbon monoxide (CO) sensing module for CO toxic gas monitoring and enhanced fire detection.
- For use with 4007ES, and 4010ES or 4100ES fire alarm control units (FACUs) with software revision 2.01.02 or higher.
- For use with 4100U FACUs with software revision 12.05 or higher.
- CO sensor bases require a TrueAlarm photoelectric, photo/heat or heat sensor. Order separately.
- Model 4098-9770 incorporates standard features.
- Model 4098-9771 incorporates standard features and a piezoelectric sounder.
- CO sensor bases are multi-point devices, consume only one IDNet address, and receive communications and sensor power from the IDNet channel. The sounder base requires separate 24 VDC system power or NAC connection.
- Listed to UL 268, Smoke Detectors for Fire Alarm Signaling Systems and UL 2075, Gas and Vapor Detectors and Sensors; allowing systems to be listed to Standard 2034, Single and Multiple Station Carbon Monoxide Alarms.
- Listed by ULC to CSA 6.19-01 Residential Carbon Monoxide Alarming Devices.
- Three types of CO influenced operation are available; UL 2034 CO alarm detection; UL 2075 CO (OSHA) level monitoring for ventilation control; and multi-criteria fire sensor analysis with algorithms that combines optical and CO gas monitoring information.

CO sensor base operation with a photoelectric or photo/heat sensor

- Independent sensor operation or selectable multi-sensor modes of False Alarm Reduction or Faster Detection.
- False Alarm Reduction analyzes CO and photoelectric sensor information together and rejects non-fire conditions such as steam, dust, and aerosols that can cause false alarms.
- The Faster Detection, increased sensitivity algorithm analyzes CO and photoelectric sensor information. It can increase photoelectric sensitivity for high value locations such as museums and electrical equipment rooms if CO is present.

Sounder base operation

- You can connect the sounder base to a FACU NAC through the 4905-9835 Temporal Code Module to provide temporal code 3 (TC3) for fire, or temporal code 4 (TC4) for toxic carbon monoxide alarms.
- You can use the 4905-9835 module to code other, non-fire, dedicated carbon monoxide notification appliances. Refer to data sheet (S4905-0006).
- You can manually activate the sounder from the FACU.
- Sounder operation is listed to UL 464 as an audible notification appliance.

FACU operation summary

- CO sensor data is stored and analyzed at the FACU. A new CO Service Report incorporates information access.
- 4007ES, 4010ES, and 4100ES FACUs display 10 year end of life status indications. CO sensor expiration notices occur in 12 months and in 6 months, to enable service replacement planning.
- 4100U FACUs display 5 year end of life status indications with the 12 and 6 month replacement notices.
- Analog sensor information is digitally transmitted to the host FACU through IDNet communications for processing to evaluate and track status.
- Carbon monoxide concentration in ppm (parts per million) is available for viewing from the FACU user interface.
- For OSHA compliant CO gas sensing, you can program the CO condition level by concentration. It must be greater than 30 ppm.
- 4100ES Audio FACUs can provide a CO Relocation Message with Temporal Code 4 tone and Voice Evacuation. Reference UCSET1393, refer to (S4100-0034).

General features:

- Sensors are wall or ceiling mountable.
- Operation of a CO sensor base with heat sensor incorporates dual independent sensor operation.
- New CO test mode enables functional testing of each sensor technology, this includes the CO sensor.
- Optional accessories include remote alarm LED, alarm relay, and mounting adapter plate.
- Designed for EMI compatibility.
- Includes magnetic test.

Replacing the CO sensor element

You can replace the CO sensor element when it reaches end of its service life. To access the CO sensor replacement cartridge CORC, 4098-9747, remove the interchangeable sensor head that features tamper monitoring. Sensor removal causes a trouble condition.

CO Sensor Base description

Carbon monoxide (CO) is an odorless, colorless, tasteless gas produced by the incomplete combustion of heating fuels such as wood, coal, heating oil, and natural gas. CO is also a byproduct of many materials experiencing unintentional fire or even incipient fire conditions. Monitoring of CO levels can warn of physically harmful concentrations, however, sensing of CO levels less than the harmful level can also provide improved understanding of incipient fire conditions when evaluated in combination with photoelectric fire sensor information from the same location.

Simplex CO sensor bases combine an electrolytic CO sensing module with a TrueAlarm analog sensor to provide a single, multiple sensing assembly that uses one system address. You can enable or disable the CO sensor, use it in LED/Switch modes and custom control, and you can make it public for communication across a fire alarm Network.

CO sensor operation is similar to other TrueAlarm sensors such as photoelectric or heat. It incorporates current analog values, average analog value, **No Answer** troubles, **Wrong Device** troubles, over threshold, concentration in ppm, and monitors for the presence of the CO sensor. Base mounted address selection allows the address to remain with its location when the sensor is removed for service or type change. Address access is from the front, under the removable sensor. An integral red LED flashes to indicate power-on, or continually on for alarm or trouble, and also includes a test mode status. See [Figure 2](#). Detailed status is available at the FACU.

* This product has been approved by the California State Fire Marshal (CSFM) pursuant to Section 13144.1 of the California Health and Safety Code. See CSFM Listing 7300-0026:330 for allowable values and/or conditions concerning material presented in this document. Listings and approvals under Simplex.

CO sensing, detailed operation

Toxic gas sensing, UL 2034/UL 2075

For CO toxic gas detection, the bases provide toxic gas sensing to the UL 2034 and UL 2075 standards. You can select toxic gas sensing at the same time as any of the combined CO photo fire detection modes.

Toxic gas sensing, OSHA compliant

For OSHA compliant gas sensing you can select the threshold level, greater than 30 ppm, at the FACU. Select the threshold level as required for the application, for example for ventilation control. See [FACU operations](#) for additional OSHA CO monitoring information.

Enhanced fire sensing

Each sensor sends an analog measurement digitally communicated to the FACU for analysis. The FACU uses these analog values separately, or combined, to evaluate for conditions indicative of fire, incipient fire, excessive heat, and freeze warning. For fire, the addition of a CO sensor includes two new selectable modes of operation: nuisance alarm reduction mode and faster fire detection mode. These two modes were developed based on the results of extensive tests of actual fires, performed under a wide variety of conditions.

Nuisance alarm reduction mode

This mode enables the host FACU to combine photoelectric sensor input and CO sensor level input to reduce false alarms caused by non-fire conditions. The following are examples of non-fire conditions: steam from bathroom showers, particles from dusty environments, aerosols from personal care products, tobacco smoke, cooking smoke, or other similar conditions.

Nuisance alarm reduction details

For applications of anticipated nuisance alarm conditions, photoelectric sensitivity is normally selected for 3.7%/ft smoke obscuration. However, the addition of CO sensing allows the host FACU to apply software verification similar to the timed alarm verification feature often used with conventional smoke detection.

Faster fire detection

The faster fire detection mode correlates the outputs of the CO sensor and the photoelectric sensor for increased sensitivity. You can use this mode for applications where faster response to incipient or slow building fires is required and appropriate to the environment. This mode incorporates earlier detection compared to a standard sensitive photoelectric sensor setting. It also incorporates more false alarm reduction compared to use of a sensitive setting in an area not normally considered appropriate.

Faster fire detection details

You can select TrueAlarm photoelectric sensors to be as sensitive as 0.2%/ft obscuration for applications evaluated as appropriate to that level.

However, if the environment is not suitable for that sensitivity level, you can use the faster fire detection mode to select the photoelectric sensor as a standard 2.5%/ft obscuration. With the presence of a significant level of CO, the combination of CO and photo sensing input enables an equivalent sensitivity that approaches 0.5%/ft obscuration. The host FACU tracks two photoelectric sensitivities:

- The sensitivity selected for photoelectric operation only. For example 2.5%.
- The CO correlation sensitivity that it adjusts depending on the amount of CO present.

FACU operations

Smoke sensor features

- Sensitivity monitoring that satisfies NFPA 72 sensitivity testing requirements.
- Automatic individual sensor calibration checking to verify sensor integrity.
- Automatic environmental compensation.

- Available multi-stage alarm operation.
- Display of sensitivity directly in percent for each foot.
- Monitoring of peak activity for each sensor.
- Alarm set point.
- Time of day or multi-stage alarm selection.

Sensor alarm and trouble LED indications

The sensor base LED pulses to indicate communications with the FACU. If a sensor is in alarm, or has a trouble condition, the status annunciates at the FACU and the base LED turns on continually. During a system alarm, the FACU controls LEDs such that a trouble indication returns to pulsing to help identify the sensors in alarm.

Reported CO sensor troubles:

- Disabled
- Almost expired 12 months.
- Almost expired 6 months.
- Expired (End of Life)
- Short
- Sensor missing or failed.

Trouble details

Almost Expired is similar to the **Almost Dirty** trouble for a photoelectric sensor. The **Expired** trouble is similar to the **Dirty** trouble for a TrueAlarm photoelectric sensor. CO sensor technology does not support automatic sensitivity testing and drift compensation as is available with a photoelectric sensor. End of useful CO sensor life is based upon a set 10 year operational lifetime, 5 years for 4100U FACUs, tracked by date code built into the CO sensor module electronics. Although the CO sensor continues to function after the **Expired** trouble is indicated, replacement is required to ensure proper detection accuracy.

FACU test mode

In this mode, you can functionally test the CO sensor, and installed heat or smoke sensors. Test mode is available in the host FACU. In the CO test mode, the internal multiple sensor analysis algorithms are disabled. This means you can quickly test each sensor individually or simultaneously, depending on the test equipment. You can perform CO testing with a Solo Model 332 aerosol dispenser, or equivalent. Testing is available through your local authorized Autocall product supplier. When you activate individual sensors during the test, the base LED displays continually on. See [Application reference](#) for more information.

OSHA CO monitoring

For OSHA compliant gas sensing, FACU software supports custom programming based upon CO concentration levels. For example, turn on ventilation if the CO level is greater than X ppm and turn off ventilation when the level drops less than Y ppm, or select either value as a range if required. This is separate from alarm set points.

Multi-point allocation

4007ES, 4010ES, and 4100ES FACUs only require one host FACU for each CO sensor base. For 4100U FACUs, the requirement is three points at the host FACU for each CO sensor base with the multi-sensor, and two points for the other sensors. Depending on CO sensor base and sensor choice, you can make up to seven points public to a connected Fire Alarm Network. Each CO sensor base uses a single address with sub-points layered underneath, for example 1-1-0, 1-1-1, 1-1-2, ..., 1-1-6. Additional multi-point allocation detail is described in reference data sheet.

CO sensor base power requirements

IDNet communications provides power for the standard CO sensor base. No additional wiring is required for upgrading of existing installed TrueAlarm sensor bases. CO sensor sounder bases require system supplied separate 24 VDC, or NAC, wiring, the same as the standard sounder base.

Accessories

2098-9808, Remote red LED Alarm Indicator mounts on a single gang box to provide status indications where the sensor location might not be readily visible. See [Figure 2](#).

4098-9822, LED Annunciation Relay activates when the base LED is on continually, indicating a local alarm or trouble. Contacts are DPDT, rated 2 A at 30 VDC; 1/2 A at 120 VAC for transient suppressed loads (requires external 24 VDC coil power).

Figure 2: 2098-9808 Remote red LED Alarm Indicator

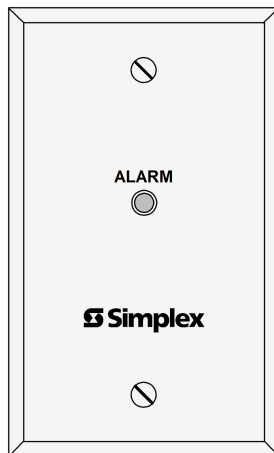

Application reference

Determine sensor locations after careful consideration of the physical layout and contents of the area.

For fire alarm applications:

Refer to *NFPA 72, the National Fire Alarm and Signaling Code*

On smooth ceilings, smoke sensor spacing of 30 ft (9.1 m) can be used as a guide.

For detailed application information:

Refer to *4098 Detectors, Sensors, and Bases Application Manual, 574-709*.

For toxic gas sensor placement and mounting:

- Refer to *NFPA 720, Standard for the Installation of Carbon Monoxide (CO) Warning Equipment in Dwelling Units*
- As in NFPA 720, Section 5.1 (2005 edition): *5.1.1 A carbon monoxide alarm or detector shall be centrally located outside of each separate sleeping area in the immediate vicinity of the bedrooms. 5.1.2 Each alarm or detector shall be located on the wall, ceiling, or other location as specified in the installation instructions that accompany the unit.*

TrueAlarm CO service reports

TrueAlarm CO service reports contain information about the CO sensors programmed in the FACU. They display pertinent data such as current concentration value in ppm, End of Life date, and current state. You can use this report to determine which sensors require attention. [Figure 3](#) shows 10 year life tracking with a 4007ES/4010ES/4100ES.

Figure 3: CO service reports

```

Service Port Page 1
REPORT 6 : TrueAlarm CO Report 12:34:56am MON 06-JUN-14
-----
Channel 1 (M1)
Zone          Current      End of
Name          Value       Life Date  State
-----
M1-1-2      Conference Room 17 CO Toxic Gas  457PPM    30-MAY-24  PRI
M1-2-2      Boiler Room CO Toxic Gas         0PPM      30-MAY-24  NOR
TRUE ALARM CO REPORT COMPLETED
Press RETURN for next Screen OR CTRL-X to abort
    
```

TrueAlarm Analog Sensor features

- Sealed against rear air flow entry.
- Electronics are EMI/RFI shielded.

Heat sensing:

You can select rate compensated, fixed temperature sensing with or without rate-of-rise operation

Table 1: Rated spacing distance between sensors

Fixed Temp. Setting	UL and ULC Spacing	FM Spacing, Either Fixed Temperature Setting
135° F (57.2° C)	60 ft x 60 ft (18.3 m)	20 ft x 20 ft (6.1 m) for fixed temperature only; RTI = Quick
155° F (68° C)	40 ft x 40 ft (12.2 m)	50 ft x 50 ft (15.2 m) for fixed temperature with either rate-of-rise selection; RTI = Ultra Fast

Smoke Sensors:

- Photoelectric technology sensing.
- 360° smoke entry for optimum response.
- Built-in insect screens.

4098-9714 Photoelectric Sensor

TrueAlarm photoelectric sensors use a stable, pulsed infrared LED light source and a silicon photodiode receiver to provide consistent and accurate low power smoke sensing. Seven levels of sensitivity are available for each individual sensor, ranging from 0.2% to 3.7% for each foot of smoke obscuration. Sensitivities of 0.2%, 0.5%, and 1% are for special applications in clean areas. Standard sensitivities are 1.5%, 2.0%, 2.5%, 3.0%, and 3.7%. Application type and sensitivity are selected and then monitored at the FACU. For detailed application information about sensitivity selection, refer to the *4098 Detectors, Sensors, and Bases Application Manual (574-709)*.

The sensor head design incorporates 360° smoke entry for optimum smoke response. Due to its photoelectric operation, air velocity is not normally a factor, except for impact on area smoke flow.

Figure 4: Dimension and Feature Reference, Photoelectric or Multi-Sensor on CO Sensor Base

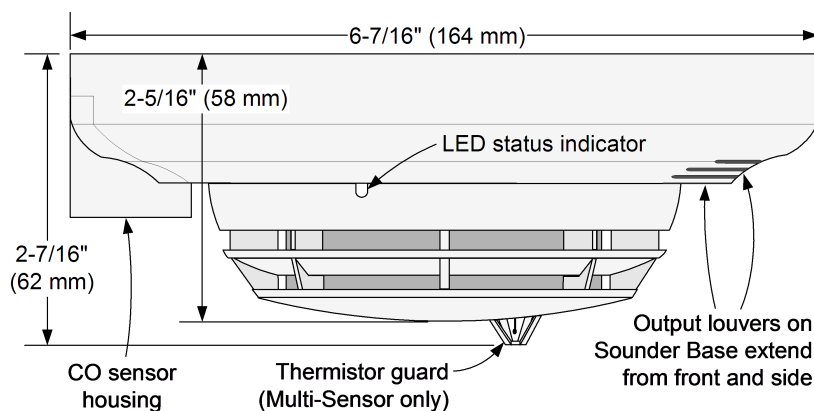

4098-9764 Multi-Sensor

TrueAlarm multi-sensors combines the performances of TrueAlarm photoelectric smoke sensing with TrueAlarm thermal sensing to provide both features in a single assembly. Each sensing element sends data for evaluation at the FACU where the following four independent detection modes are evaluated:

- Fixed temperature heat detection.
- Rate-of-rise heat detection.
- TrueAlarm photoelectric smoke detection.
- And TrueSense correlation detection.

TrueSense analysis correlates thermal activity and smoke activity at a single multi-sensor location by use of an extensively tested covariance relationship. As a result, TrueSense detection improves response to conditions indicative of faster acting, hot flaming fires when compared to the response of photoelectric smoke activity or thermal activity alone.

4098-9733 Heat Sensor

TrueAlarm heat sensors are self-restoring and provide rate compensated, fixed temperature sensing, selectable with or without rate-of-rise temperature sensing. Due to its small thermal mass, the sensor accurately and quickly measures the local temperature for analysis at the FACU.

At the FACU, you can select rate-of-rise temperature detection for 15°F (8.3°C) or 20°F (11.1°C) for each minute. Fixed temperature sensing is independent of rate-of-rise sensing and programmable to operate at 135°F (57.2°C) or 155°F (68°C). In a slow developing fire, the temperature might not increase rapidly enough to operate the rate-of-rise feature. However, an alarm will be initiated when the temperature reaches its rated fixed temperature setting.

You can program TrueAlarm heat sensors as a utility device to monitor for temperature extremes in the range from 32°F to 155°F (0°C to 68°C). This feature can provide freeze warnings or alert to HVAC system problems.

Figure 5: 4098-9733 Heat Sensor with CO Sensor Base (with CO Sensor Housing facing forward)

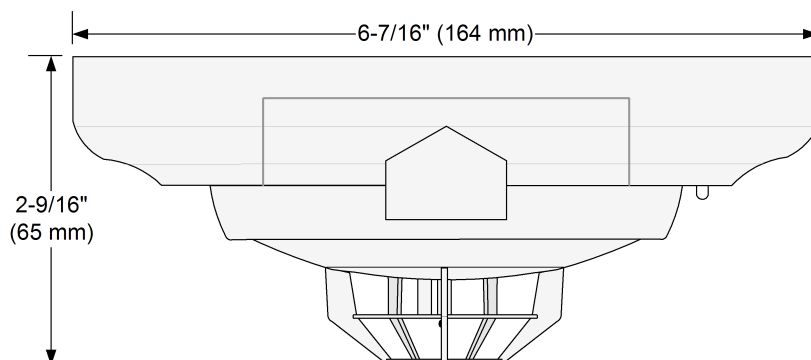

WARNING: In most fires, hazardous levels of smoke and toxic gas can build up before a heat detection device initiates an alarm. In cases where Life Safety is a factor, the use of smoke detection is highly recommended.

TrueAlarm analog sensing product selection chart

Table 2: TrueAlarm CO sensor bases

Model	Description	
4098-9770	CO Base, Standard operation	Select TrueAlarm sensor from Table 3
4098-9771	CO Base with Sounder	

Table 3: TrueAlarm sensors, select one for each CO Sensor Base

Model	Description	
4098-9714	Photoelectric Smoke Sensor	See selection Table 5 for available operation modes
4098-9764	Multi-Sensor Photoelectric and Heat Sensing	
4098-9733	Heat Sensor	

Table 4: CO Base Replacement CO Cartridge and accessories (ordered separately as required)

Model	Description		Mounting requirements
4098-9747	CO Replacement Cartridge (CORC)		
Solo 332	Aerosol Dispenser, suitable for larger diameter detectors. You can use it for CO or smoke testing		
Solo C3	CO Aerosol Canister (case of 12)		
Model	Description		Mounting requirements
4098-9832	Adapter Plate, required for surface mounted 4 in. electrical boxes		See Installation reference .
2098-9808	Choose one if required	Remote red LED Alarm Indicator on single gang stainless steel plate	Single gang box, 1-1/2 in. minimum depth
4098-9822	Choose one if required	Relay, tracks base led status (unsupervised, to be mounted only in base electrical box)	Mounts in base electrical box (requires 1-1/2 in. extension on 4 in. square or octagonal box)

CO Sensor Base operation options with sensor choice

For [Table 5](#), see note 1 after the table.

Table 5: Operational mode choices

Sensor choice	Mode	False Alarm Reduction	Faster Detection	TrueSense Photo/Heat	Photo Fire	Heat Fire. See note 2.	Utility Temp.	Ion Fire	CO Toxic Gas See note 3.
Photoelectric Smoke Sensor 4098-9714	1	Yes	—	—	—	—	—	—	option
	2	—	Yes	—	option	—	—	—	option
Photo/Heat Multi-Sensor 4098-9764	3	Yes	—	—	—	option	option	—	option
	4	—	Yes	—	option	option	option	—	option
	5	—	—	Yes	option	option	option	—	option
Heat Sensor 4098-9733	6	—	—	—	—	Yes	option	—	option
	7	—	—	—	—	option	Yes	—	option

Note:

- Duct detection modes are not applicable and are not available. See [FACU operations](#) for FACU point requirement information.
- Heat Fire Mode is 135°F or 155°F, fixed or rate-of-rise.
- You can select CO Toxic Gas operation as follows:
 - Supervisory. This is not recommended if communicated off-site.
 - Priority 2. This is preferred if communicated off-site.
 - Utility.

Specifications

Table 6: General operating specifications

Specification	Rating	
Communications and sensor supervisory power	IDNet communications, one address for each base	
Communications and sounder power connections	Screw terminals for in/out wiring, 18 to 14 AWG (0.82 mm ² to 2.08 mm ²)	
Remote LED alarm indicator	Current	1 mA typical supplied from communications, no impact to alarm current
	LED connections	Color coded wire leads, 18 AWG (0.82 mm ²)
UL Listed temperature range	32° F to 100° F (0° C to 38° C)	
Operating temperature range	with 4098-9733	32° F to 122° F (0° C to 50° C)
	with 4098-9714 or 4098-9764	15° F to 122° F (-9° C to 50° C)
Humidity range	15 to 95% RH	
CO Sensor Base Air Velocity Ratings for each Sensor	Photoelectric Sensor 4098-9714 and Multi-Sensor 4098-9764 Air velocity = 0-1000 ft/min (0-305 m/min)	
Housing color	Frost white	

Table 7: Sounder operation

Specification	Rating	
Sounder voltage	18 to 32 VDC from steady external source or from NAC.	
Alarm current (Sounder On)	17 mA at 24 VDC, 24 mA maximum at 32 VDC	
Sounder output	88 dBA minimum at 10 ft (3 m) as in UL Standard 464, Audible Signaling Appliance; UL Standard 268, Smoke Detectors for Fire Protective Signaling Systems and CSA 6.19-01.	
Sounder power supervision (Selectable)	Supervised	Select for continuous 24 VDC power. Loss of power is communicated to FACU.
	Unsupervised	Select when connected to NAC for sounder power. NAC incorporates supervision.
NAC powered operation	When in alarm, will sound when NAC is in alarm, allowing synchronized pattern (Temporal or March Time, etc.) controlled by the NAC control.	

Table 8: Reference for CO monitoring

Requirement	Concentration	Alarm window	
Requirements reference for UL 2034 and CSA 6.19-01	Response time	70 ±5 ppm	60 to 240 minutes
		150 ±5 ppm	10 to 50 minutes
		400 ±10 ppm	4 to 15 minutes
	False alarm resistance	30 ±3 ppm	No alarm for 30 days
		70 ±5 ppm	No alarm for 60 minutes

Table 8: Reference for CO monitoring

Requirement	Concentration	Alarm window
Additional UL 2034 CO sensor toxic gas monitoring details	For CO levels greater than 40 ppm, the CO alarm level for each sensor is determined by calculations performed at the FACU based on the time integrated CO levels measured at the sensor. Levels less than 40 ppm are not tracked. While tracking levels greater than 40 ppm, if the concentration is less than 40 ppm for periods of time, the time to alarm is extended accordingly.	
UL 2075 reference, commercial OSHA type operation; utility point mode	With custom control at the FACU, Utility Point operations can be performed at lower CO concentration levels than those of UL 2034 Example: Start ventilation after 5 minutes at 25 to 35 ppm and also alarm at a reading higher than that range, but lower than UL 2034 allows	

Table 9: 4098-9822 Unsupervised Relay option

Specification	Rating
Externally supplied relay voltage	18 to 32 VDC, steady source recommended. Wires to remote LED leads.
Alarm current	13 mA from separate 24 VDC supply
Contact ratings, DPDT contacts for resistive/suppressed loads	Power limited rating: 2 A at 30 VDC
	Non-power limited rating: 1/2 A at 120 VAC
Relay operation	Tracks base LED status, relay is on with trouble or alarm at the base

Additional information reference

Table 10: Datasheets with additional information

Product	Datasheet	Product	Datasheet
Temporal Code 4 Module	S4905-0006	4100ES Control Panels with EPS Power Supplies	S4100-0100
Standard Bases	S4098-0019	4100ES Standard Control Panels	S4100-0031
Isolator Bases	S4098-0025	4100ES Audio Control Reference	S4100-0034
IDNet Isolator2 Bases	S4098-0026	4010ES Control Panels	S4010-0004
Standard Sounder Base	S4098-0028	4007ES Hybrid Control Panels	S4007-0001
TrueSense Multi-Sensor	S4098-0024		

Installation reference

Figure 6 shows the requirements for electrical boxes supplied by others.

Without a relay:

- 4 in. octagonal or 4 in. square, 1 1/2 in. deep
- Single gang, 2 in. deep.

With a relay, 4 in. octagonal or 4 in. square, 1 1/2 in. deep, with 1 1/2 in. extension ring.

The box depth shown is the minimum. For flush mounting, mount it even with the final surface, or with up to 1/4 in. (6.4 mm) maximum recess.

Note: The single gang RACO adapter plate is required when a 4 in. square box, supplied by others, is used.

The optional relay mounts in a base electrical box and it requires additional volume. Relay dimensions are shown in the following figure.

Figure 6: Installation reference for boxes and adapter plate

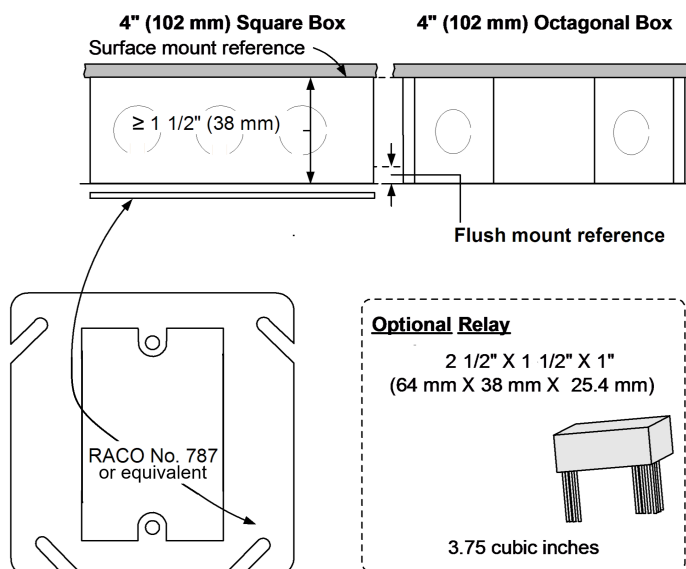
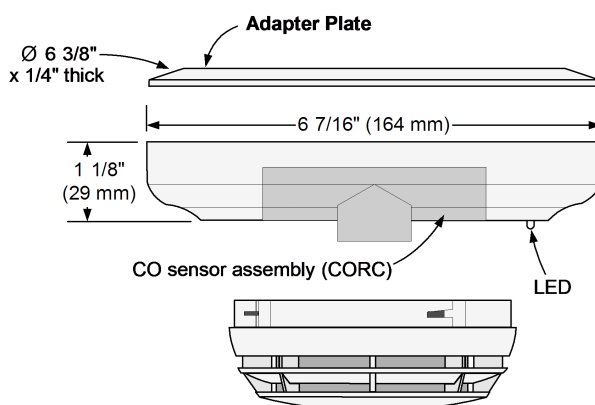

Figure 7 shows the adapter plate that is required for mounting to surface mounted boxes. The adapter plate mounts inverted. The CO sensor assembly (CORC) is shaded. The LED status indicator is also shown. A photoelectric sensor is shown as a reference.

Figure 7: Installation reference for sensors



Note:

1. Figure 6 and Figure 7 show optional 4098-9822 relay and 4098-9832 adapter plate.
2. Before determining box size, review actual wire size, wire count, box type, and whether the 4098-9822 relay is used.
3. Mounting to flush mounted box also fits single gang handy box, 2 1/8 in. (51 mm) deep if wiring allows. Not applicable if you use the 4098-9822 relay.
4. For surface mounted boxes, use a 4 in. square box with single gang adapter plate (RACO No. 787 or equal, by others) or 4 in. octagonal box, both require 4098-9832 Adapter Plate.
5. When 4098-9822 relay is used, mount relay in electrical box and use 1 1/2 in. extension ring, by others, on 4 in. square or octagonal box of 1 1/2 in. or 2 1/8 in. depth as required.
6. Refer to *CORC Replacement Instructions (579-791)* for CO cartridge installation and replacement, and *Sensor Base Installation Instructions (574-707)* for additional information.

