

# SIEMENS

## Installation Instructions

### MODEL ICP-B6

### Intelligent Control Point

The Model ICP-B6 Intelligent Control Point from Siemens Industry, Inc. can be used as an independent, remotely located telephone zone, a speaker zone (25V or 70.7V RMS), or notification appliance circuit (NAC), depending on how it is configured. It communicates through the analog loop of the MXL/MXLV System.

## OPERATION

Up to 12 ICP-B6s can connect to each analog loop of the MXL/MXLV. These modules must be connected to the first 12 address locations on the analog loop.

The 24 VDC power input for each ICP-B6 comes from either the MMB, the PSR, or from an auxiliary power supply which is power limited and UL listed for fire protective signaling use and is rated between 24 and 27.3 VDC. Each ICP-B6 can be assigned a 32-character, custom alphanumeric message.

Each module uses one address on either the analog loop of the ALD-2I module or the analog loop of the MMB board. (See Figure 1) The ICP-B6 is programmable for different usages.

For additional information on the MXL/MXLV System, refer to the *MXL/MXLV Manual, P/N 315-092036*.

## Addressing and Testing

Use the DPU Device Programming Unit or the FPI-32 Programmer/Tester (*SensorLINK*) to program and test the module.

**NOTE:** With FPI-32 Rev. 1.3 software, only **1=MXL** mode should be used when programming a device.

## To Set the ICP-B6 Module Address:

1. Plug the programming cable of the DPU or FPI-32 Programmer/Tester (*SensorLINK*) into the two-pin receptacle on the ICP-B6. (See Figure 2 for location only.)
2. Set the system address for the ICP-B6 by following the instructions in the *FPI-32 (SensorLINK) Programmer/Tester Manual, P/N 315-090077*, or the *DPU User's Manual, P/N 315-033260*, as applicable.

**Remove all system power before installation, first battery and then AC. (To power up, connect the AC first, then the battery.)**

**All wiring must comply with national and local codes.**

**The ICP-B6 should be installed in a UL listed electrical box. (See Figure 10.)**

## Analog Loop

The ICP-B6 communicates with the MXL through its analog addressable loops. These loops are on either the MMB or on the optional ALD-2I module of the MOM-4. They may be wired for Class A (Style 6) or Class B (Style 4). Figure 1 shows both wiring types and the connections to either the MMB or to the MOM-4 when the ALD-2I module is used. The table on the following page lists the maximum output currents allowed.

The ICP-B6 module can be used in four different ways:

**1. Using the ICP-B6 as an NAC Module**

This notification appliance application uses the principle of polarity reversal when there is an alarm. Figure 2 shows the polarity connection in a supervisory condition. When using the ICP-B6 as a supervised NAC output module with notification appliance devices, cut jumper JP2. Refer to Figure 2 for additional connection and jumper information, and to P/N 315-096363 for a list of compatible devices.

When used as an NAC module, the output circuit is power limited. The ICP-B6 maximum current is 1.5A at 24 VDC. If the 24 VDC is lost or the NAC line is broken or shorted, the trouble condition INPUT DEVICE RESPONSE TOO LOW displays at the MXL/MXLV control panel. Refer to Figures 3 and 4 for the connections used with the TRI-60/B6 module and the PSR-1 module, respectively. See the **Line Resistance** chart for the allowable line resistance for each ICP-B6 output circuit.

MAXIMUM ALLOWABLE ICP-B6 OUTPUT CIRCUIT LINE RESISTANCE FOR SPECIFIED DC RISER CURRENT AND LINE RESISTANCE						
MAXIMUM DC RISER CURRENT (in Amps)	DC RISER RESISTANCE (in Ohms)					
	0.1 Ohm	0.25 Ohm	0.5 Ohm	0.75 Ohm	1 Ohm	1.5 Ohms
8	2.46	1.67	.33	--	--	--
7	2.53	1.83	.66	--	--	--
6	2.60	2.00	1.00	--	--	--
5	2.67	2.16	1.33	.5	--	--
4	2.73	2.33	1.67	1.00	.33	--
3	2.80	2.50	2.00	1.50	1.00	--
2	2.86	2.67	2.33	2.00	1.67	1.00
1	2.93	2.83	2.67	2.50	2.33	2.00
.5	2.96	2.92	2.83	2.75	2.67	2.50
MAXIMUM LOOP RESISTANCE FOR EACH ICP-B6 ON RISER						

**NOTES:**

1. Resistances specified are for both wires.
2. If higher currents are required, Siemens Industry, Inc. recommends using a local auxiliary supply which is UL listed for fire protection signaling use. The supply should be rated between 24 and 27.3 VDC.

**ELECTRICAL RATINGS**

Active 5VDC Module Current	0mA
Active 24VDC Module Current	10mA
Standby 24VDC Module Current	10mA

<b>ALD-2I</b>		<b>ALD-2I</b>		<b>MMB</b>	<b>MMB</b>
<b>MOM-4</b>		<b>MOM-4</b>		<b>TB2</b>	<b>TB3</b>
<b>TB2</b>		<b>TB1</b>			
<b>LOOP 1</b>	<b>LOOP 2</b>	<b>LOOP 1</b>	<b>LOOP 2</b>	<b>LOOP 1</b>	<b>LOOP 2</b>
4	8	4	8	4	4
3	7	3	7	3	3
2	6	2	6	2	2
1	5	1	5	1	1

LOOP RESISTANCE 100 OHMS MAX  
18 AWG MINIMUM WIRE

NO EOL DEVICE REQUIRED  
SUPERVISED, POWER LIMITED PER NEC 760

ALL WIRING MUST CONFORM TO NATIONAL AND  
LOCAL ELECTRICAL CODES

### ANALOG LOOP CONNECTION

(NO T-TAPPING ALLOWED)  
OPERATES IN FULL CONFORMANCE  
WITH STYLE 6 (CLASS A)

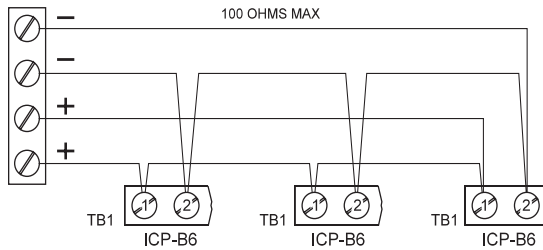

### ANALOG LOOP CONNECTION

(T-TAPPING ALLOWED)  
OPERATES IN FULL CONFORMANCE WITH STYLE 4 (CLASS B)

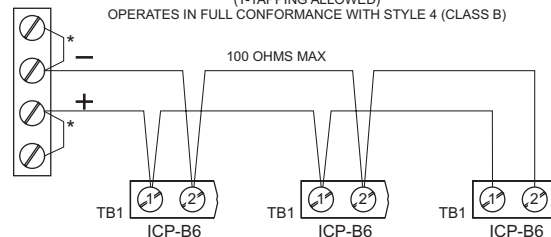

\*JUMPERS CAN BE REMOVED FROM MMB-3 WITH CSGM CONFIGURATION

**Figure 1**  
**Analog Loop Connections**

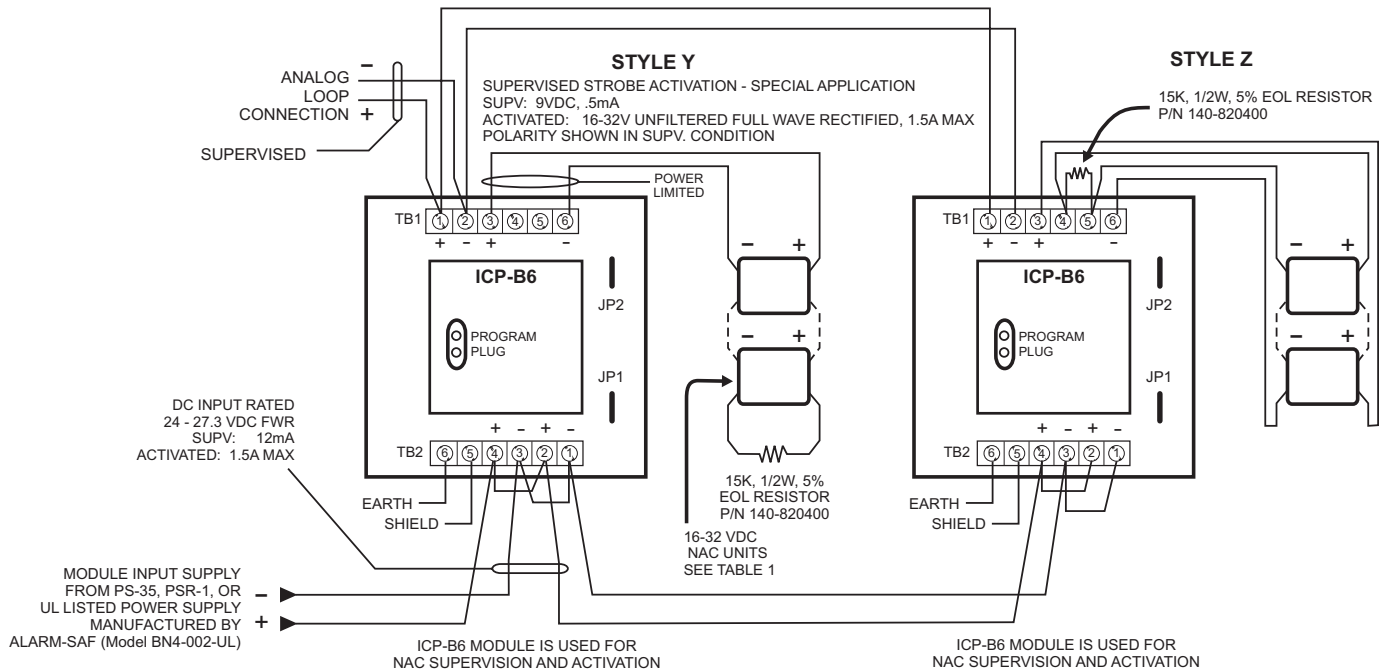

**ELECTRICAL:**  
INPUT DC SUPPLY: 24-27.3 VDC, 18mA MAX  
SUPERVISORY OUTPUT: 9 VDC, 0.5mA  
SPECIAL APPLICATION  
ACTIVATED: 16-32V UNFILTERED FULL WAVE RECTIFIED  
1.5A, POWER LIMITED

- NOTES:**
1. ALL WIRING MUST COMPLY WITH NATIONAL AND LOCAL CODES.
  2. POSITIVE AND NEGATIVE GROUND FAULT DETECTED AT <5K OHMS FOR TERMINALS 3-6.
  3. FOR SYNCHRONIZATION OF NOTIFICATION APPLIANCES USE EITHER DSC, DSC-W, OR PAD-3.

**Figure 2**  
**ICP-B6 Used as a Strobe Module**

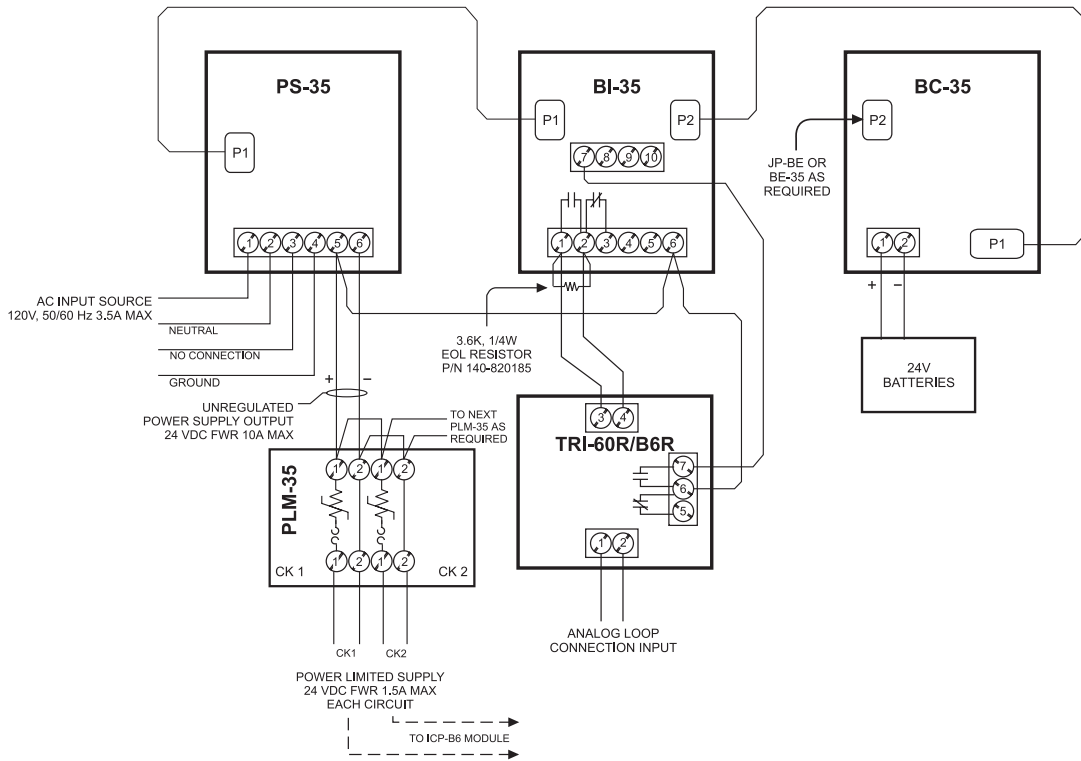

**Figure 3**  
**ICP-B6 Connections When Using TRI-60/B6**

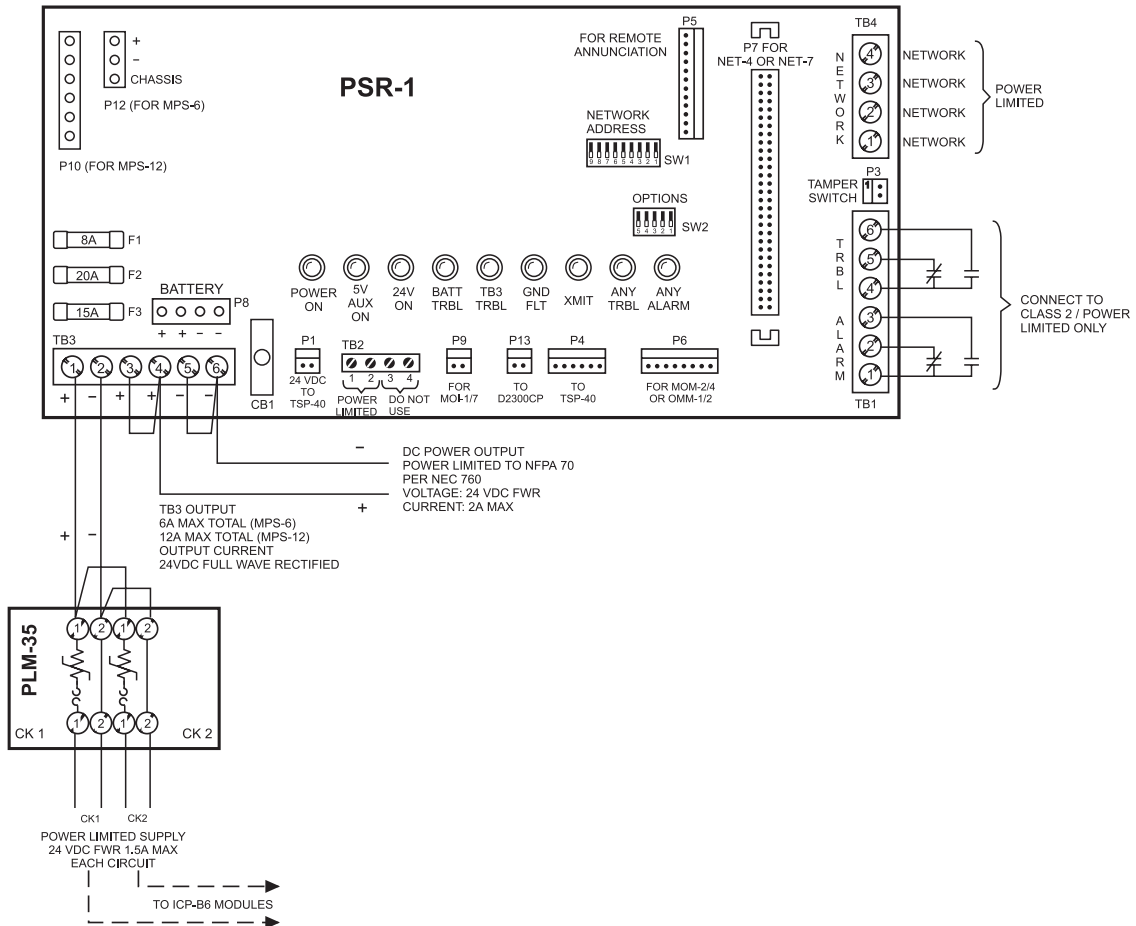

**Figure 4**  
**ICP-B6 Connections Using PSR-1**

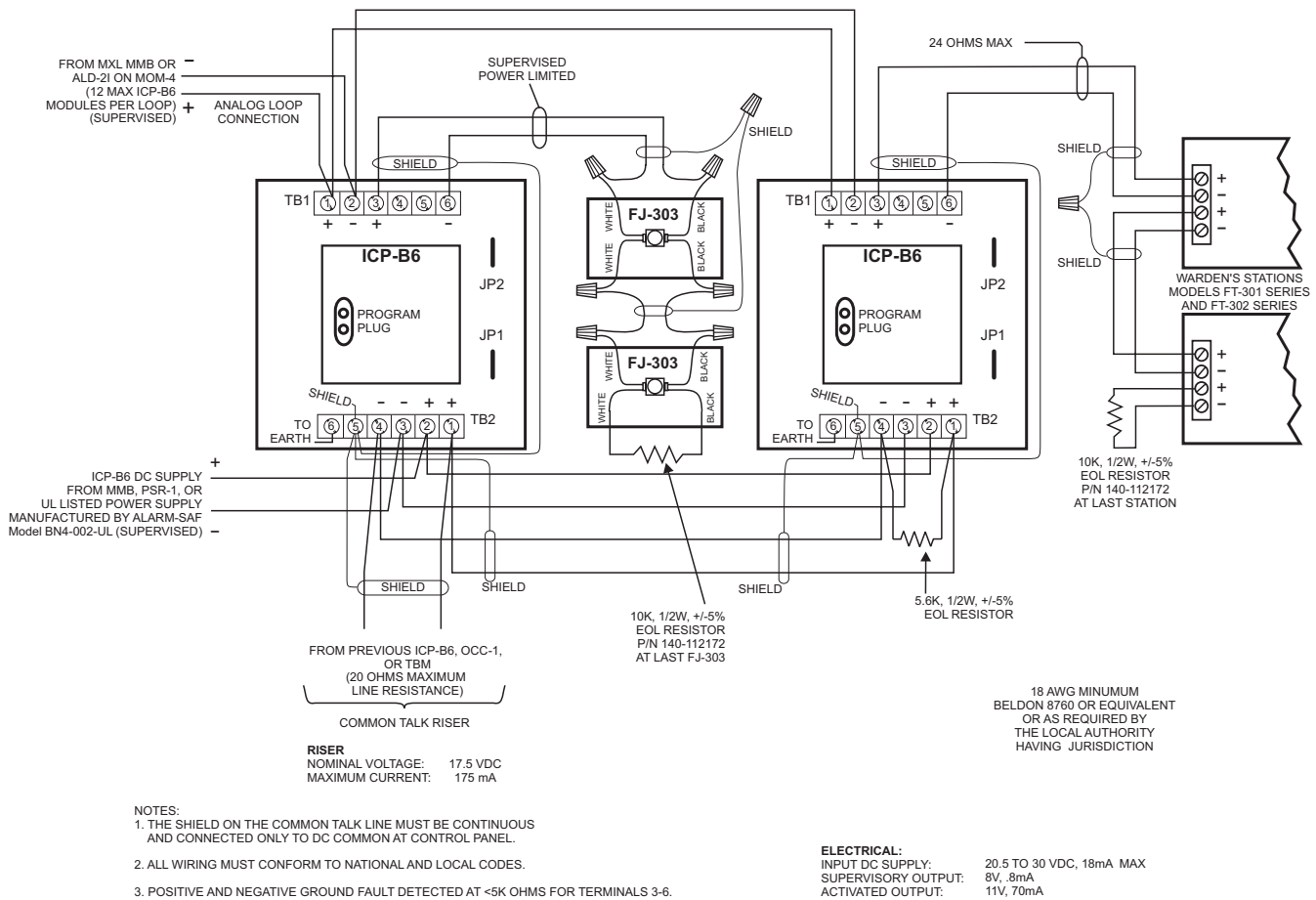

**Figure 5**  
**ICP-B6 Used as a Telephone Zone**

## 2. Using the ICP-B6 as a Telephone Zone

When the ICP-B6 is used as a telephone zone module, the 24 VDC provides supervision, trouble, and call-in conditions. If the 24 VDC is lost, the trouble condition INPUT DEVICE RESPONSE TOO LOW displays at the MXL/MXLV and an LED for that zone lights at the VSM-1 module.

The supervised telephone common talk riser starts at the TBM module in the MME-3 back-box. The Class B shielded cable connects continuously to each ICP-B6 with a 5.6K end of line device. Tie the shield of these riser wires and the shield of the zone output wires together using terminal 5 of TB2 and **isolate them from the system circuits and the earth ground.**

Connect the supervised individual zone output connections from each ICP-B6 to the field telephone with shielded cable. Terminate them at the last station with a 10K ohm end of line resistor. As with the common talk line described in the paragraph above, be sure that **the shield is continuous and isolated**

**from both system circuits and earth ground and that the shields are connected together using terminal 5 of TB-2.**

## 3. Using the ICP-B6 as a 70 Volt Speaker Zone

When the ICP-B6 is used as a speaker zone, the 24 VDC provides the supervision. If the 24 volts is lost or there is an open or shorted speaker output line, the trouble condition INPUT DEVICE RESPONSE TOO LOW displays at the MXL/MXLV and the related zone LED on the VSM-1 lights.

The 70.7V RMS audio input comes from the amplifier via the ASC-2 Amplifier Supervision card. The ASC-2 supervises the audio connection path to the ICP-B6 and provides up to 100 watts of power. The ASC-2 can be used as Style Y (Class B) or Style Z (Class A). Refer to the *ASC-2 Instructions*, P/N 315-092085.

When the ICP-B6 is used as a speaker zone, the output speaker lines are supervised and power limited. The audio output cannot exceed

25 watts. Connect the speaker output as either Style Y (Class B) or Style Z (Class A). Figure 6 gives the approximate decibel loss for the total speaker zone wire length for various wire gauge sizes.

When using the ICP-B6 as a 70.7V RMS speaker zone, cut the JP1 jumper. (See Figure 8.)

#### 4. Using the ICP-B6 as a 25 Volt Speaker Zone

When the ICP-B6 is used as a speaker zone, the 24 VDC provides the supervision. If the 24 volts is lost or there is an open or shorted speaker output line, the trouble condition INPUT DEVICE RESPONSE TOO LOW displays at the MXL/MXLV and the related zone LED on the VSM-1 lights.

The 25V RMS audio input comes from the amplifier via the ASC-2 Amplifier Supervision card. The ASC-2 supervises the audio connection path to the ICP-B6 and provides up to 100 watts of power. The ASC-2 can be used as Style Y (Class B) or Style Z (Class A). Refer to the *ASC-2 Instructions*, P/N 315-092085.

When the ICP-B6 is used as a speaker zone, the output speaker lines are supervised and power limited. The audio output cannot exceed 35 watts. Connect the speaker output as either Style Y (Class B) or Style Z (Class A). Figure 7 gives the approximate decibel loss for the total speaker zone wire length for various wire gauge sizes.

When using the ICP-B6 as a 25V RMS speaker zone, cut the JP2 jumper (See Figure 9).

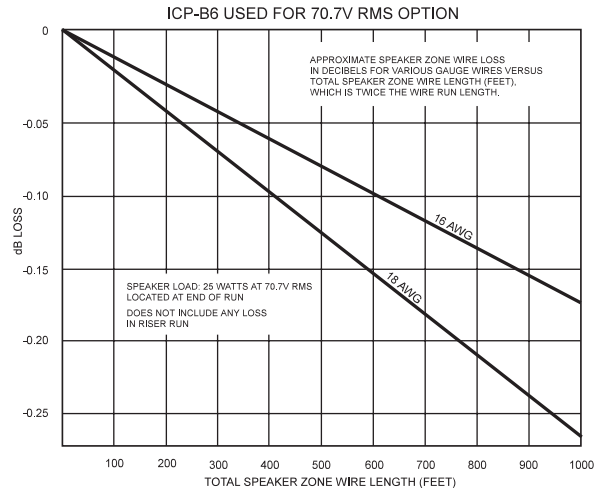

**Figure 6**  
**Approximate Speaker Zone Wire Loss with the 70.7V Option**

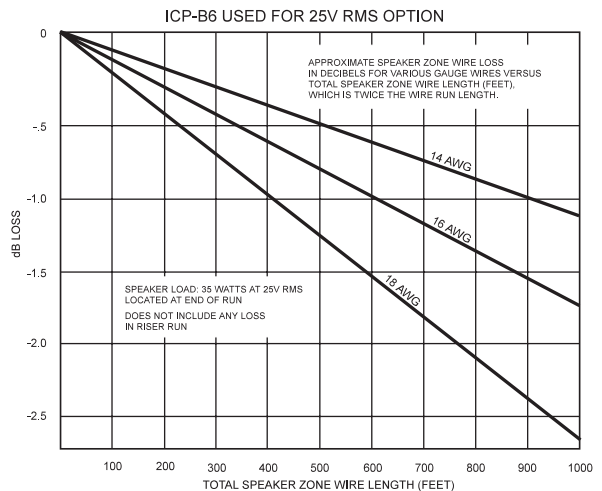

**Figure 7**  
**Approximate Speaker Zone Wire Loss with the 25V Option**

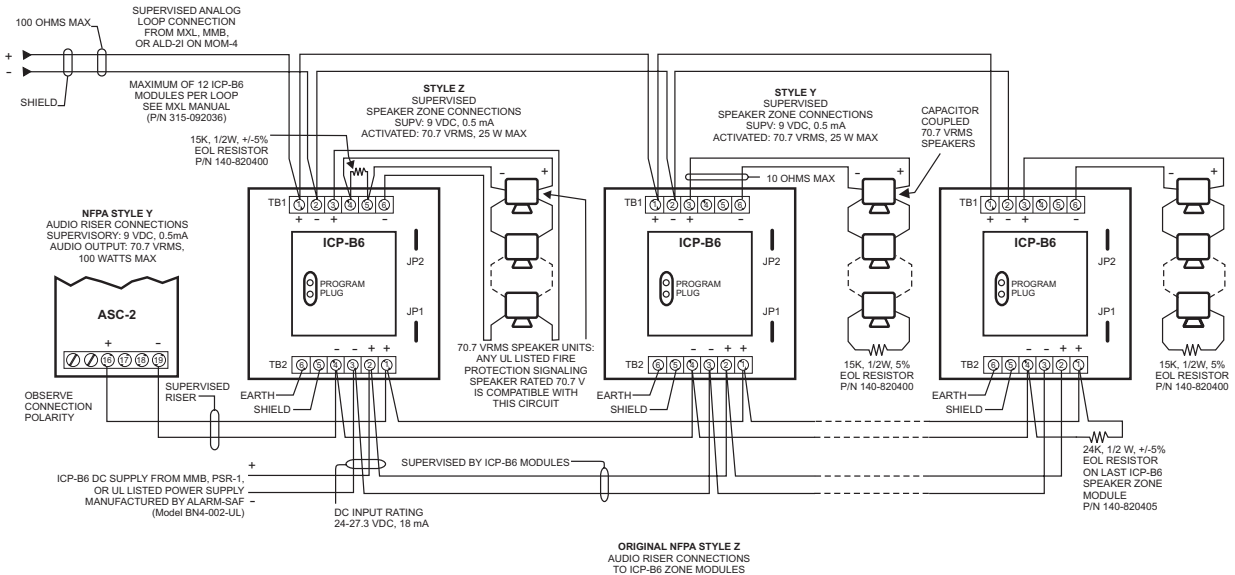

All wiring must comply with national and local codes.

**ELECTRICAL:**  
 INPUT DC SUPPLY: 24-27.3 VDC, 18mA MAX  
 SUPERVISORY OUTPUT: 9 VDC MAX, 0.5mA  
 ACTIVATED OUTPUT: 70.7 V, 25 WATTS MAX

**Figure 8**  
 ICP-B6 Used as a 70.7V Speaker Zone

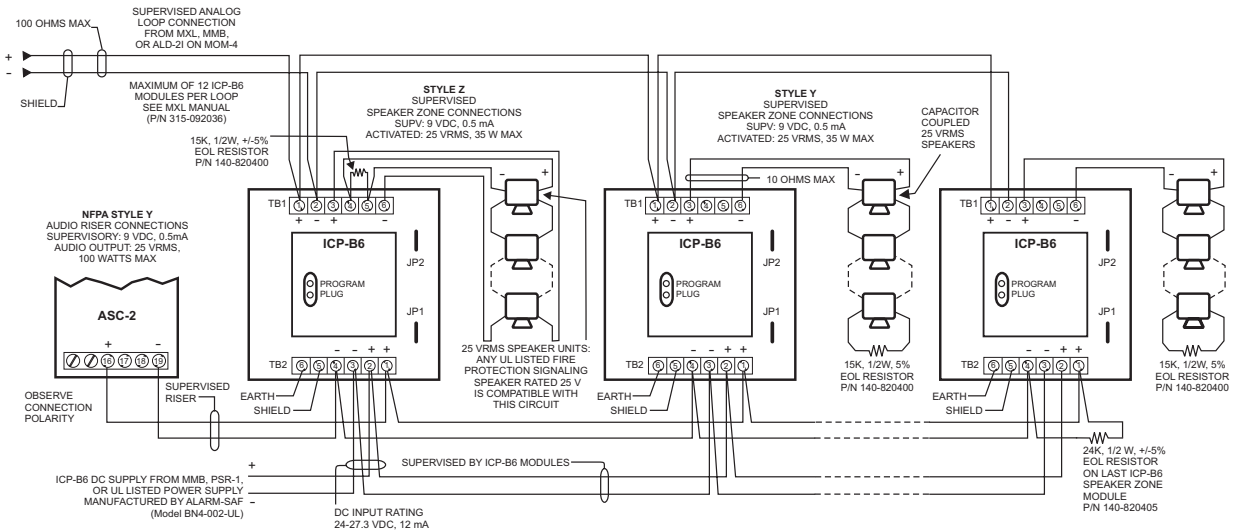
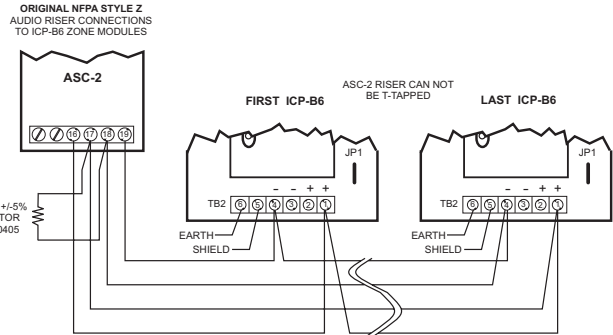

All wiring must comply with national and local codes.

**ELECTRICAL:**  
 INPUT DC SUPPLY: 24-27.3 VDC, 18mA MAX  
 SUPERVISORY OUTPUT: 9 VDC MAX, 0.5mA MAX  
 ACTIVATED OUTPUT: 25 V, 35 WATTS MAX

**Figure 9**  
 ICP-B6 Used as a 25V Speaker Zone

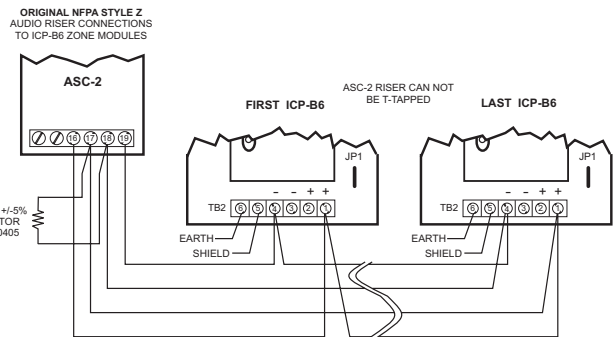

## MOUNTING

(See Figure 10)

1. Use a standard 3 1/2-inch deep, double gang electrical switchbox or a 4-inch square electrical box that is 2 1/2 inches deep with either a 1 1/2-inch deep extension or a 1 1/4-inch deep plaster ring extension.
2. Connect the field wiring. Insert the ICP-B6 into the box and fasten the module plate to the box.

NOTE: When using the double gang switchbox or the plaster ring extension, use the same four screws to fasten both the module and the blank plate (user supplied).

3. Cover the module front plate with a 4-inch blank plate (user supplied) and fasten with two plate screws.

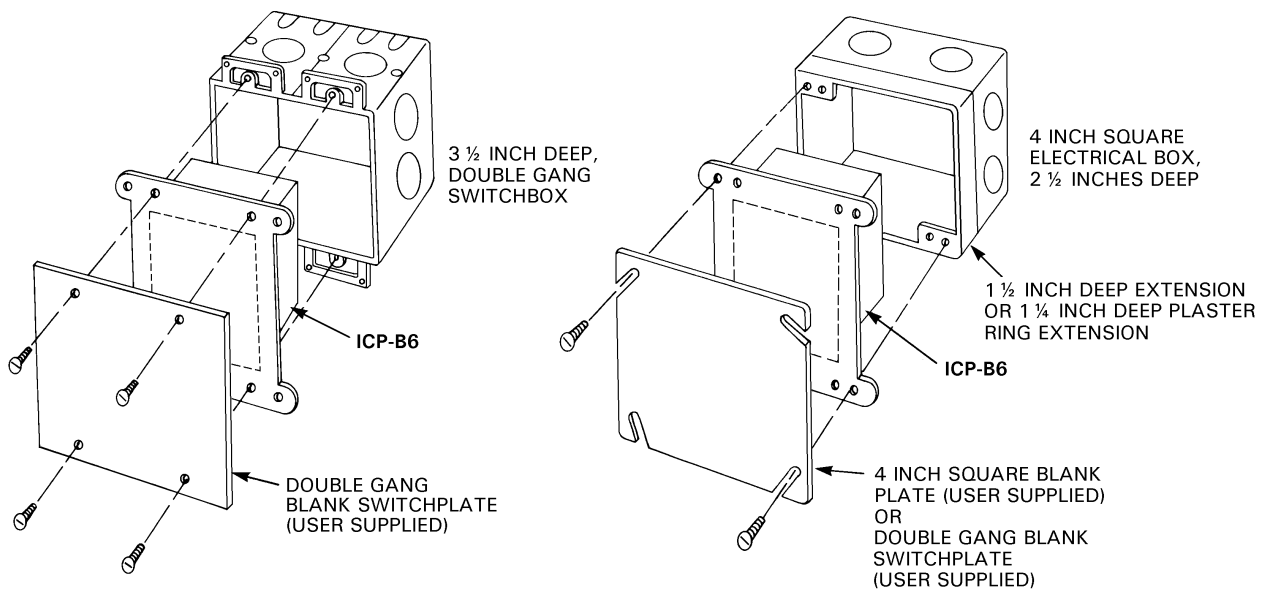

**Figure 10**  
**Mounting the ICP-B6**